

# IR Receiver Module for PCM Remote Control Systems

## General Description

The AT1..A-series are miniaturized receivers for infrared remote control systems. PIN diode and preamplifier are assembled on lead frame, the epoxy package is designed as IR filter.

The demodulated output signal can directly be decoded by a microprocessor. The main benefit is the reliable function even in disturbed ambient and the protection against uncontrolled output pulses

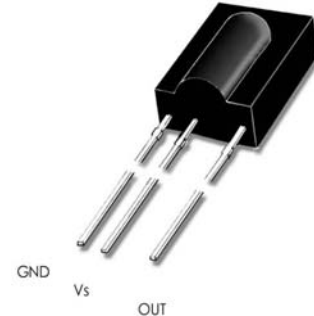

## Features

- Photo detector & Preamplifier in one package
- TTL and CMOS compatibility
- Output active low
- Enhanced immunity against all kinds of disturbance light
- No occurrence of disturbance pulses at the output
- Suitable burst length  $\geq 10$  cycles/burst
- In accordance with RoHS directive

## Applications

- TV
- Audio video equipments
- Other home appliances remote control systems

## Product type number and carrier frequency

Type	fo	Type	fo
AT136A	36KHz	AT138A	38KHz
AT140A	40KHz	AT156A	56KHz

## Functional Block Diagram

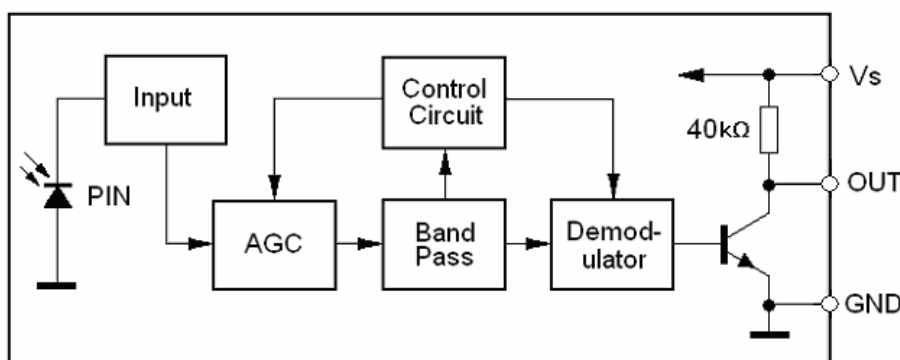

## Absolute Maximum Ratings

Parameter	Test Conditions	Symbol	Value	Unit
Supply Voltage	(Vs)	Vs	-0.3...6.0	V
Supply Current	(Is)	Is	5	mA
Output Voltage	(OUT)	Vo	-0.3...6.0	V
Output Current	(OUT)	Io	5	mA
Storage Temperature Range		Tstg	-30...+105	°C
Operating Temperature Range		Tamb	-25...+85	°C
Power Consumption	( Tamb ≤85°C)	Ptot	50	mW
Soldering Temperature	t≤10s 1mm from case	Tsd	260	°C

## Basic Characteristics

Parameter	Test Conditions	Symbol	Min	Typ	Max	Unit
Operating Voltage		Vs	4.5		5.5	V
Supply Current	Vs=5V Ev=0	Is	0.7	1.1	1.5	mA
Transmission Distance	940nm IR emitter AT205, If=0.4A	d		35		m
Directivity	Angle of 1/2 transmission distance	θ		±45		deg
Peak Wavelength		λ		940		nm
Output Voltage Low		VOSL			250	mV
Output Pulse Width	TON=TOFF=600μs		500		800	μs

## APPLICATION Circuit

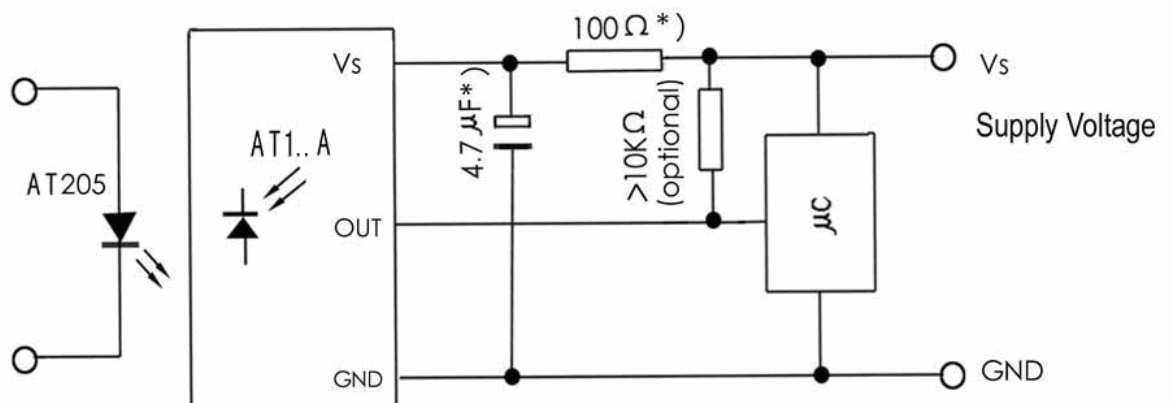

\*) recommended to suppress power supply disturbances

Package Outline

Dimensions in mm:

