

AT225-14-80

DATA SHEET

REV. : 1.0

DATE : 12-NOV.-2007

■ **FEATURES:**

- High reliability.
- High radiant intensity.
- Peak wavelength at 850nm.
- Standard T-1 3/4(φ5MM).
- Lead Free product, in compliance with RoHS.

■ **DESCRIPTIONS:**

- AT225-14-80 is a high response speed and high radiant intensity infrared emitting diode with exceptionally stable characteristics and high illumination sensitivity.
- Moulded in 5mm diameter and water clear package.

■ **APPLICATIONS:**

- Free air transmission system.
- Security System.
- Infrared applied system
- Night viewing.

■ **INTERNAL CIRCUIT:**

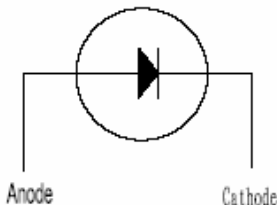

■ **DIMENSIONS:**

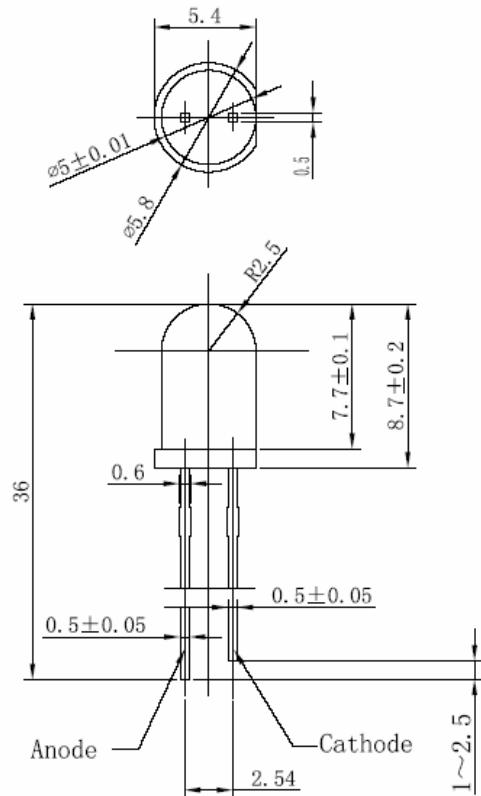

NOTE: 1. All dimensions are in millimeter, tolerance is ± 0.25 unless otherwise noted.
 2. Epoxy meniscus extends ≤ 1 mm down to the lead is allowed.

■ ABSOLUTE MAXIMUM RATINGS AT Ta=25°C

Parameter	Symbol	Ratings	Unit
Power Dissipation	P _D	120	mW
Peak Forward Current	I _{FP}	1	A
Reverse voltage	V _R	5	V
Operating Temperature	T _{opr}	-40~+85	°C
Storage Temperature	T _{stg}	-55~+100	°C
Soldering Temperature	T _{sol}	270°C for 6 sec Max (2mm from Body)	

NOTE: I_{FP} Conditions Pulse Width ≤ 100μS And Duty ≤ 1%.

■ TYPICAL ELECTRICAL & OPTICAL CHARACTERISTICS (Ta=25°C)

Parameter	Symbol	Min.	Type	Max.	Unit	Test Condition
Radiant Intensity	E _e		20		mW/Sr	I _F =20 mA
			90		mW/Sr	I _F =100 mA
Forward Voltage	V _F		1.5	1.8	V	I _F =50 mA
Reverse Current	I _R			10	μA	V _R =5V
Peak Wavelength	λ _p		850			I _F =20mA
Δλ	T _f		45		nm	I _F =20mA
View Angle	2θ _{1/2}		40		deg	I _F =20mA

■ RELIABILITY TEST ITEMS AND CONDITIONS:

NO	Item	Test Conditions	Test Hours/Cycle	Sample Quantity	Test Result
1	Solder Heat	TEMP: 270°C ± 3°C	10 SEC	11 pcs	0 DEFECT
2	Temperature Cycle	H:+85°C 60min \updownarrow 10min L:-40°C 60min	16 cycles	22 pcs	0 DEFECT
3	Thermal Shock	H:+85°C 30min \updownarrow 30sec L:-40°C 30min	10 cycles	11 pcs	0 DEFECT
4	High Temperature Storage	TEMP: +100°C	1000 HRS	22 pcs	0 DEFECT
5	Low Temperature Storage	TEMP: -55°C	1000 HRS	22 pcs	0 DEFECT
6	High Temperature High Humidity Storage	85°C/93% RH	1000HRS	22 pcs	0 DEFECT

■ TYPICAL ELECTRO-OPTICAL CHARACTERISTICS CURVES:

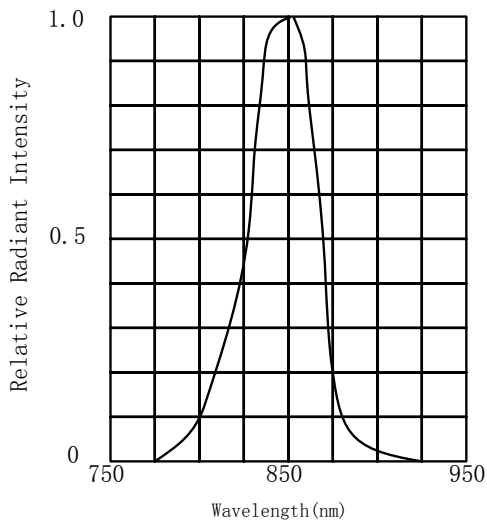

FIG. 1 SPECTRAL DISTRIBUTION

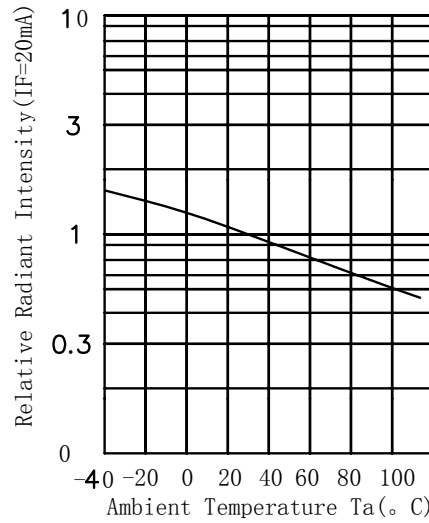

FIG. 2 RELATIVE RADIANT INTENSITY VS AMBIENT TEMPERATURE

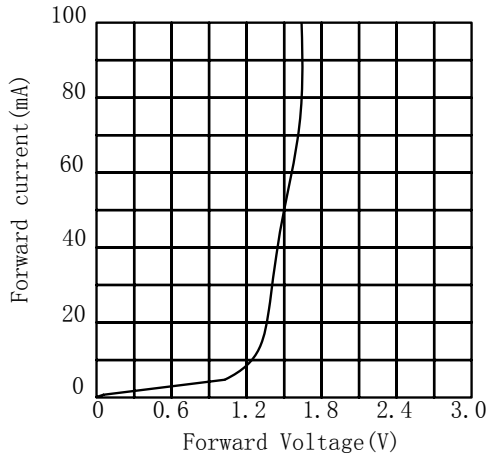

FIG. 3 FORWARD CURRENT VS FORWARD VOLTAGE

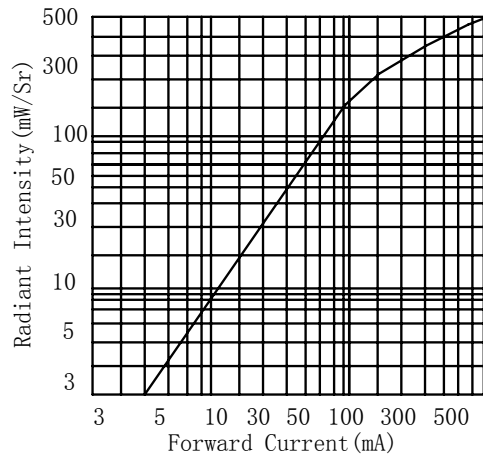

FIG. 4 FORWARD CURRENT VS RADIANT INTENSITY

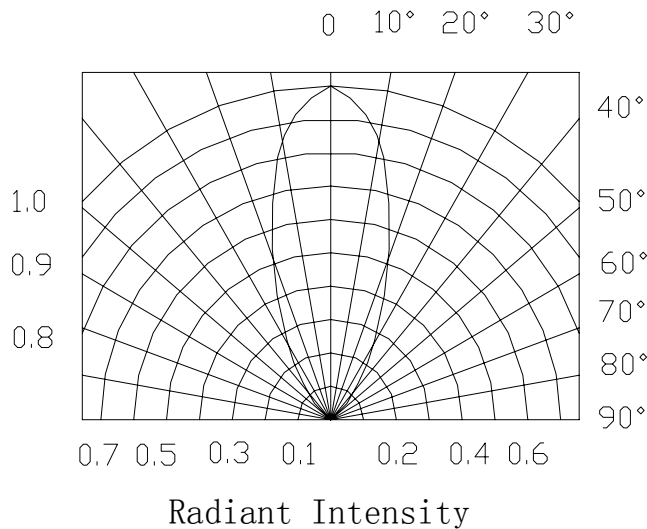

Fig.5 Angle Vs Radiant Intensity