

FIBER OPTIC TRANSMITTING MODULE
--

■ GENERAL DESCRIPTION

HKTX179D is a driver module designed for the application of high-speed optical fiber transmission. It integrates the LED driver with constant current output to reduce the complexity and the cost of the transmission module. HKTX179D can transmit with the speed up to 15Mb/s.

■ FEATURES

- 1) Conform to EIAJ standard CP-1201 (For Digital audio interfaces including fiber optic inter-connections).
- 2) TTL interface.
- 3) LED is drove by differential circuit.
- 4) +5V single power supply.
- 5) High-speed signal transmission (15M NRZ signal).
- 6) ESD tolerance IC > 8KV.
- 7) Standard package (panel mount type).

■ APPLICATIONS

- 1) Digital audio equipment: CD, MD and DVD player to sound applications for personal computers and computer entertainment systems.
- 2) Navigation system.

■ MAXIMUM RATINGS (Ta=25 °C)

Characteristic	Symbol	Rating	Units
Supply Voltage	Vcc	-0.5 to 7	V
Input Voltage	V _{IN}	-0.5 to Vcc+0.5	V
Operating Temperature	Topr	-25 to 70	
Storage Temperature	Tstg	-30 to 80	

■ RECOMMENDED OPERATING CONDITIONS AND ELECTRICAL CHARACTERISTICS (Ta=25 °C , Vcc=5V)

Characteristic	Symbol	Condition	Min	Typ	Max	Units
Operating Voltage	Vcc		2.75	3	5.25	V
Operating Current	Iop		5	5.5	6	mA
Transmitter Wavelength	λ		-	650	-	nm
Transmitter Light Power	Pf	*1	-21	-	-15	dBm
Data Rate	T	NRZ Code *2	DC	-	15	Mb/s
Pulse Width Distortion	tw	Pulse width 80ns Pulse cycle 160ns, CL=10pF Using HKRX179	-25	-	25	ns
Jitter	tj		-	1	25	ns
Low to High Delay Time	tPLH		-		100	ns
High to Low Delay Time	tPHL		-		100	ns
High Level Input Voltage	VIH	Vcc=3V or 5v	2.0	-		V
Low Level Input Voltage	VIL	Vcc=3V or 5v		-	0.8	V
High Level Input Current	IiH		-	-	20	μ A
Low Level Input Current	IiL		-	-	-0.4	mA

*1: Fiber insertion measure peak value.

*2: For data rate > 15Mb/s(NRZ), the duty factor must be such as kept 25 to 75%.

■ MECHANICAL CHARACTERISTICS (Ta=25 °C)

Characteristic	Symbol	Condition	Min	Typ	Max	Units
Insertion Force		*1	-	-	40	N
Withdrawal Force		*1	6	-	40	N
Torque for Self-Tap		Using self-tapping screw (M3*8)	60	-	100	N-cm

*1: Using standard optical fiber cable. (970/1000 μ m)

■ TEST CIRCUIT

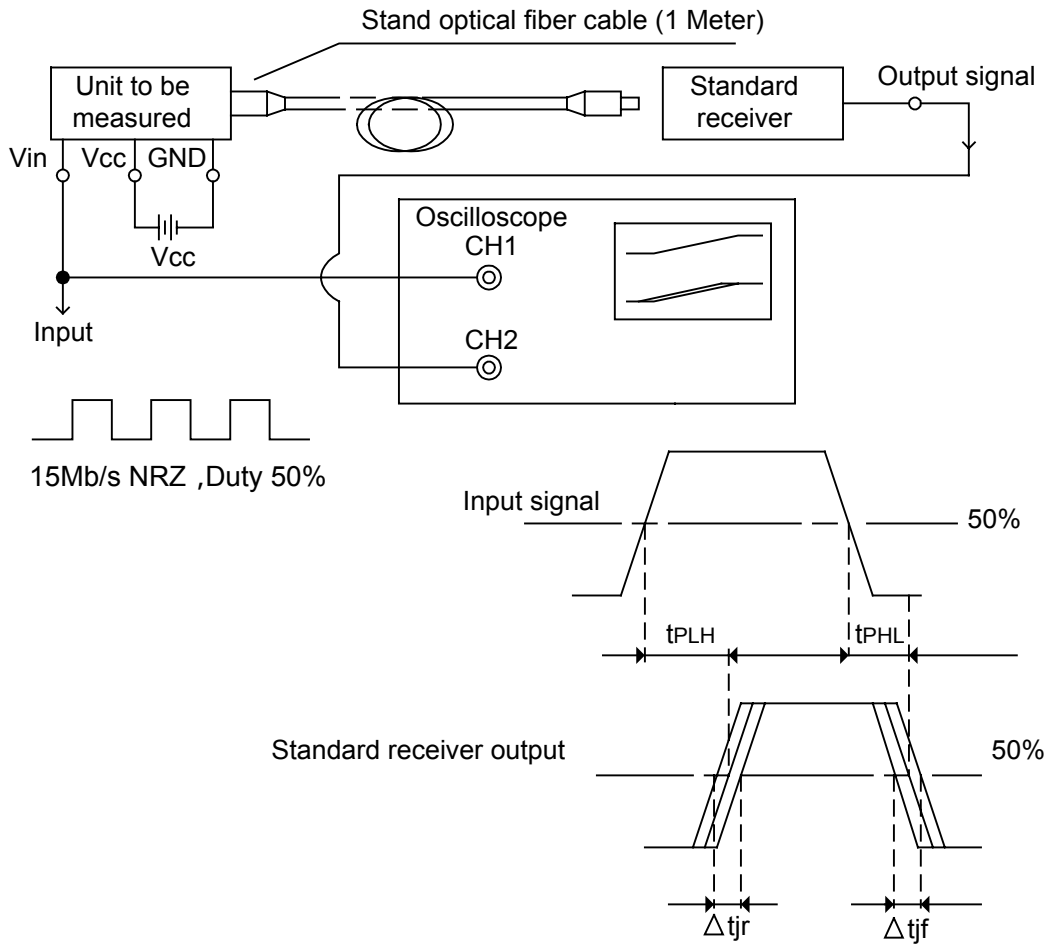

■ COMMENTS

No.	Test Item	Symbol
1	Low to High Pulse Delay Time	t_{PLH}
2	High to Low Pulse Delay Time	t_{PHL}
3	Pulse Width Distortion ; $\Delta tw = t_{PHL} - t_{PLH}$	Δtw
4	High Level Output Voltage	V_{OH}
5	Low Level Output Voltage	V_{OL}

■ HKTX179D

OUTLINE DIMENSION Unit: mm

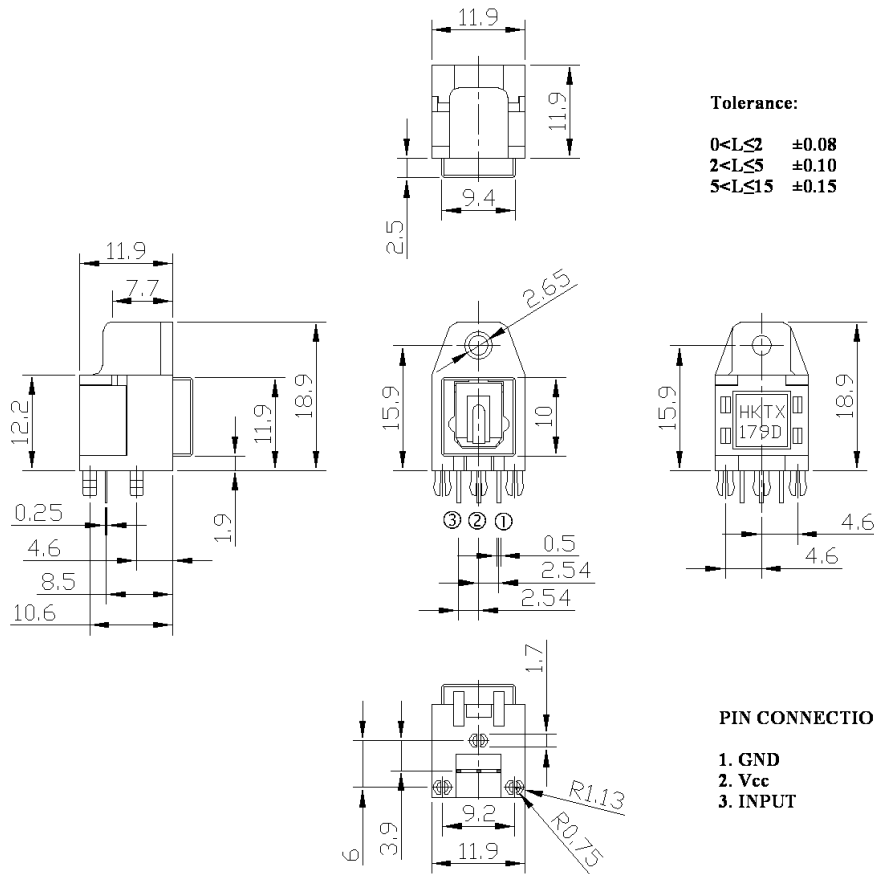

■ RECOMMENDED DRILLING AS VIEWED FROM THE SOLDERING FACE

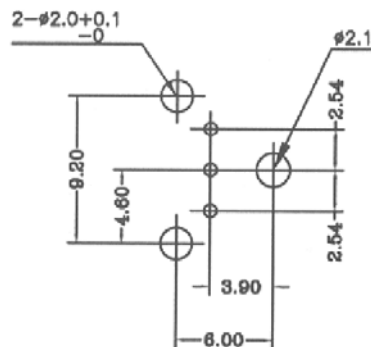

■ BLOCK DIAGRAM

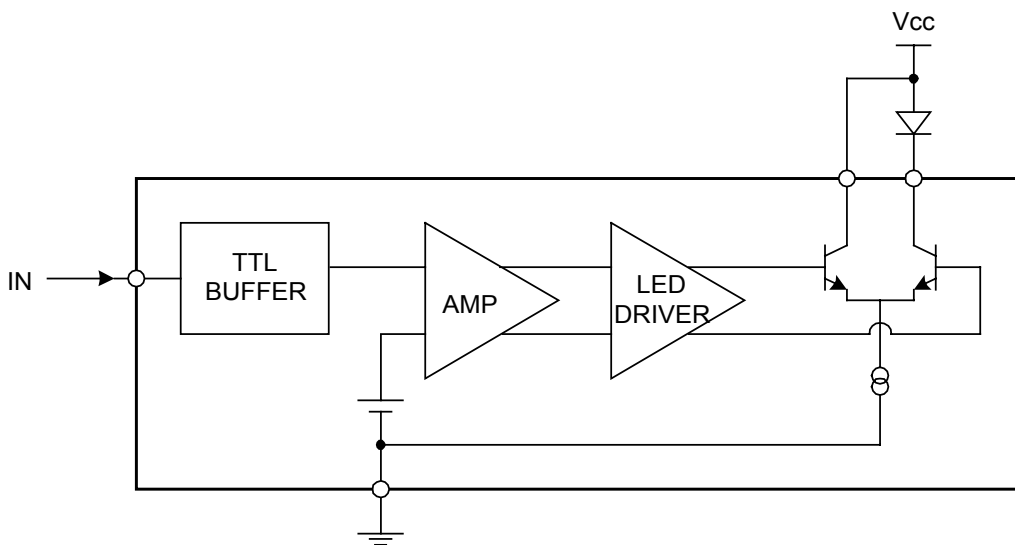

■ PRECAUTIONS DURING USE

1) Maximum rating

The maximum ratings are the limit values that must not be exceeded when using the device. Any one of the ratings must not be exceeded. If the maximum rating is exceeded, the characteristics may not be recovered. In some extreme cases, the device may be permanently damaged.

2) Life of light emitters

When the optical module is used for over a long period, degeneration of characteristics is mostly due to lowering of the fiber output power (Pf). This is caused by the degradation of the optical output of the LED's used as the light source. The cause of degradation of the optical output of the LED's may be defects in wafer crystallization or mold resin stress. The detailed causes are, however, not clear.

The life of light emitters is greatly influenced by operating conditions and usage environment as well as the life characteristics unique to the device. Thus, when selecting a light emitter and setting the operating conditions, GOOD TAKE recommends that you check the life characteristics.

Depending on the environment conditions, GOOD TAKE recommends maintenance such as regular checks on the amount of optical output.

3) Soldering

Optical modules use semiconductor devices internally. However, in principle, optical modules are optical components. At soldering, take care that flux does not contact the emitting surface or detecting surface. Also take care at flux removal after soldering. Some optical modules come with protective cap. The protective cap is used to avoid malfunction when the optical module is not in use. Note that it is not dust or waterproof.

As mentioned before, optical modules are optical components. Thus, in principle, soldering where there may be flux residue or flux removal after soldering is not recommended. GOOD TAKE recommends that soldering be performed without the optical module mounted on the board. Then, after the board is cleaned, solder the optical module manually. Do not perform any further cleaning. If the optical module cannot be soldered manually, use non-halogen (chlorine-free) flux and make sure, without cleaning, there is no residue such as chlorine. This is one of the ways to eliminate the effects of flux. In such a case, check the reliability.

4) Vibration and shock

This module is resin-molded construction with wire fixed by resin. This structure is relatively sound against vibration or shock. In actual equipment, there are some cases where vibration, shock, and stress is applied to soldered parts or connected parts, resulting in line cut. Attention must be paid to the design of the mechanism for applications that are subject to large amounts of vibration.

5) Fixing fiber optical transmitting module

Solder the fixed pin of fiber optic transmitting module HKTX179D to the printed circuit board to fix the module to the board.

6) Solvent

When using solvent for flux removal, do not use a high acid or high alkali solvent. Be careful not to pour solvent in the optical connector ports. If solvent is inadvertently poured there, clean with cotton tips.

7) Protective cap

When the fiber optic transmitting module HKTX179D is not in use, use the protective cap.

8) Supply voltage

Use the supply voltage within the Typ. Operating condition ($V_{cc} = 2.7\sim 5.5V$). Make sure that supply voltage does not exceed the maximum rating value of 7V, even instantaneously.

9) Input voltage

If a voltage exceeding the maximum rating value ($V_{cc}+0.5V$) is applied to the transmitter Input, the internal IC may degrade causing some damage. If excessive voltage due to surge may be added to the input, insert a protective circuit.

10) Soldering condition

Solder at 260 °C or less within ten seconds.

11) Precaution on waste

When discarding devices and packing materials, follow procedures stipulated by local regulations in order to protect the environment against contamination.

Compound semiconductors such as GaAs are used as LED materials for this module. When discarding waste or at final processing, attention must be paid to workers and the environment.

12) Precaution on use

GOOD TAKE is continually working to improve the quality and the reliability of its products.

Nevertheless, semiconductor devices in general can malfunction or fail due to their inherent electrical sensitivity and vulnerability to physical stress. It is the responsibility of the buyer, when utilizing GOOD TAKE products, to observe standards of safety, and to avoid situations in which a malfunction or failure of a GOOD TAKE product could cause loss of human life, bodily injury or damage to property.

In developing your designs, please ensure that GOOD TAKE products are used within specified operating ranges as set forth in the most recent product specifications.