

**FIBER OPTIC TRANSMITTING MODULE**

■ **GENERAL DESCRIPTION**

HKTX179W12 is a driver module designed for the application of high-speed optical fiber transmission. It integrates the LED driver with constant current output to reduce the complexity and the cost of the transmission module. HKTX179W12 can transmit with the speed up to 16Mb/s.



■ **FEATURES**

- 1) Conform to EIAJ standard CP-1201 (For Digital audio interfaces including fiber optic inter-connections).
- 2) TTL interface.
- 3) LED is drove by differential circuit.
- 4) Wide range for Supply Voltage (2.7V-5.5V).
- 5) High speed signal transmission (16M NRZ signal).
- 6) ESD tolerance IC>8KV.
- 7) Standard package (panel mount type).

■ **APPLICATIONS**

- 1) Digital audio equipment: CD, MD and DVD player to sound applications for personal computers and computer entertainment systems.
- 2) Navigation system.

■ **MAXIMUM RATINGS (Ta=25 °C)**

Characteristic	Symbol	Rating	Units
Supply Voltage	Vcc	-0.5 to 7	V
Input Voltage	VIN	-0.5 to Vcc+0.5	V
Operating Temperature	Topr	-20 to 70	°C
Storage Temperature	Tstg	-30 to 80	°C

■ **RECOMMENDED OPERATING CONDITIONS AND ELECTRICAL CHARACTERISTICS (Ta=25 °C , Vcc=5V)**

Characteristic	Symbol	Condition	Min	Typ	Max	Units
Operating Voltage	Vcc		2.75	3	5.25	V
Operating Current	Iop		3	5.5	6	mA
Transmitter Wavelength	$\lambda p$		-	650	-	nm
Transmitter Light Power	Pf	*1	-21	-	-15	dBm
Data Rate	T	NRZ Code *2	DC	-	16	Mb/s
Pulse Width Distortion	$\Delta tw$	Pulse width 62.5ns Pulse cycle 125ns, CL=10pF Using HKRX179	-15	-	15	ns
Jitter	$\Delta tj$		-	1	15	ns
Low to High Delay Time	tPLH		-		100	ns
High to Low Delay Time	tPHL		-		100	ns
High Level Input Voltage	VIH	Vcc=3V or 5v	2.0	-		V
Low Level Input Voltage	VI L	Vcc=3V or 5v		-	0.8	V
High Level Input Current	I IH		-	-	20	$\mu$ A
Low Level Input Current	I I L		-	-	-0.4	mA

\*1: Fiber insertion measure peak value.

\*2: For data rate > 16Mb/s(NRZ), the duty factor must be such as kept 25 to 75%.

■ **MECHANICAL CHARACTERISTICS (Ta=25 °C)**

Characteristic	Symbol	Condition	Min	Typ	Max	Units
Insertion Force		*1	-	-	39.2	N
Withdrawal Force		*1	6	-	39.2	N
Torque for Self-Tap		Using self-tapping screw (M3*8)	60	-	100	N-cm

\*1: Using standard optical fiber cable. (970/1000 um)

■ TEST CIRCUIT

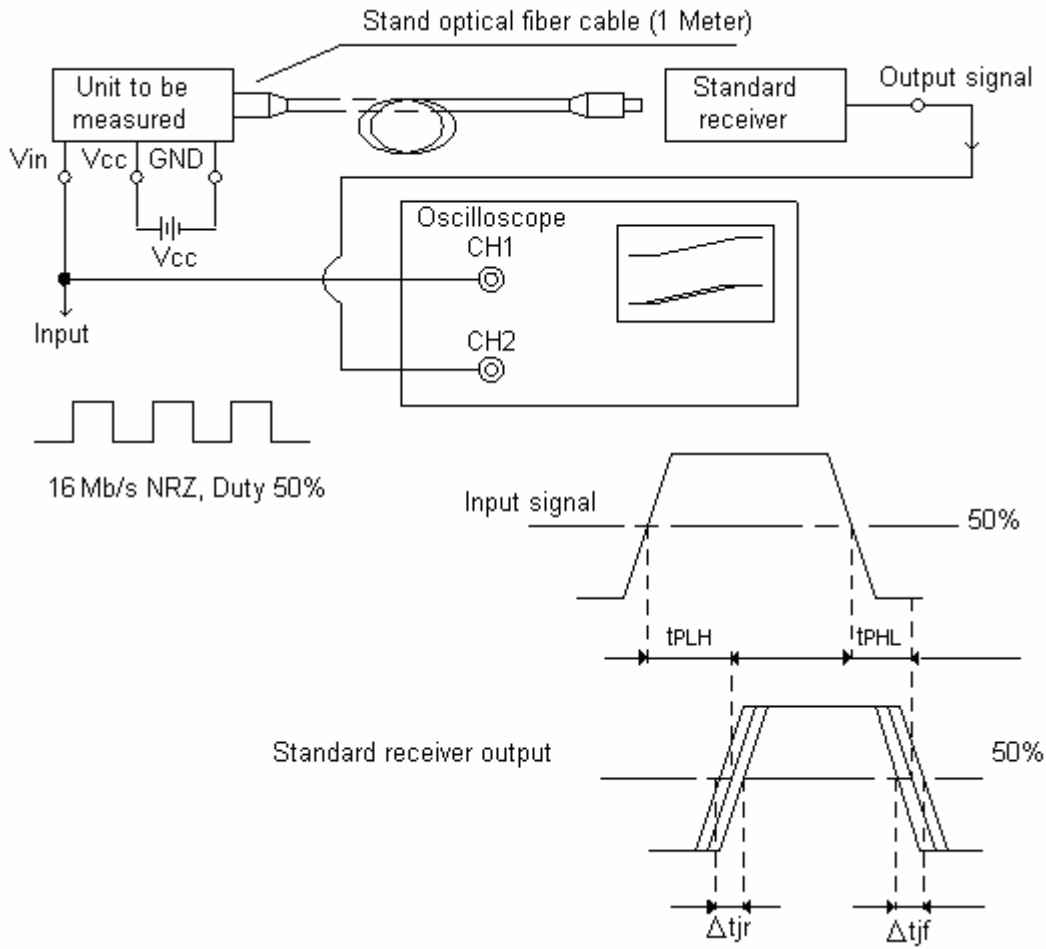

■ COMMENTS

No.	Test Item	Symbol
1	Low to High Pulse Delay Time	$t_{PLH}$
2	High to Low Pulse Delay Time	$t_{PHL}$
3	Pulse Width Distortion $\Delta tw = t_{PHL} - t_{PLH}$	$\Delta tw$
4	High Level Output Voltage	$V_{OH}$
5	Low Level Output Voltage	$V_{OL}$

■ HKTX179W12

OUTLINE DIMENSION Unit: mm tolerance ±0.3mm

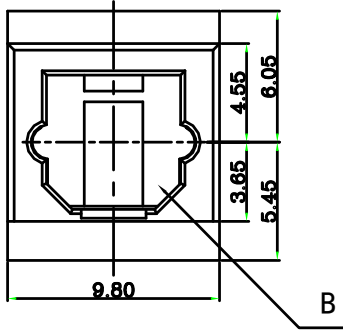

Symbol	Description	Material
A	Holder	PBT
B	Shutter	PBT
C	Fixing pin	SPCC

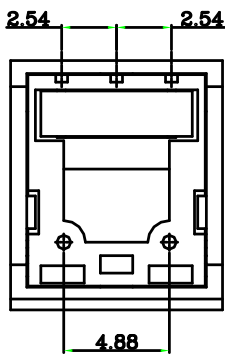
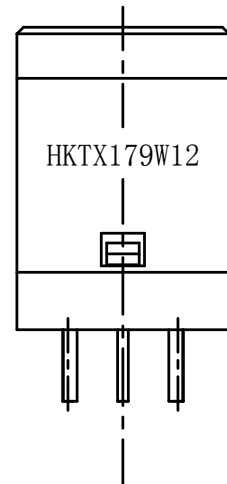
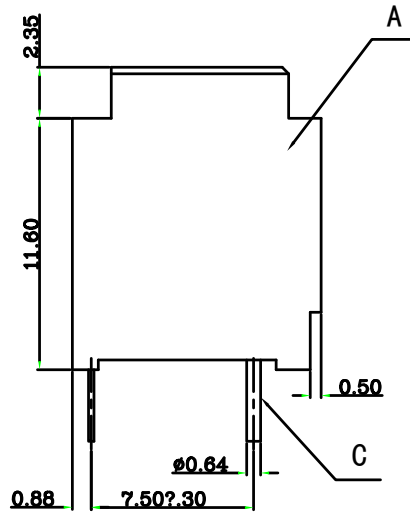
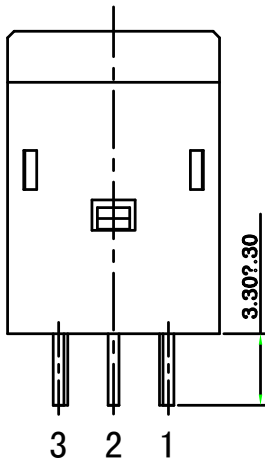

Pin Function

- 1. GND
- 2. Vcc
- 3. Vin

PCB Layout For Electrolcal Circuit (TOP VIEW)

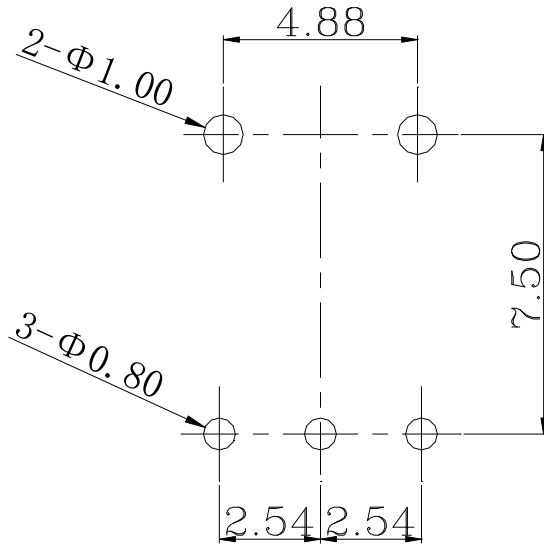

■ BLOCK DIAGRAM

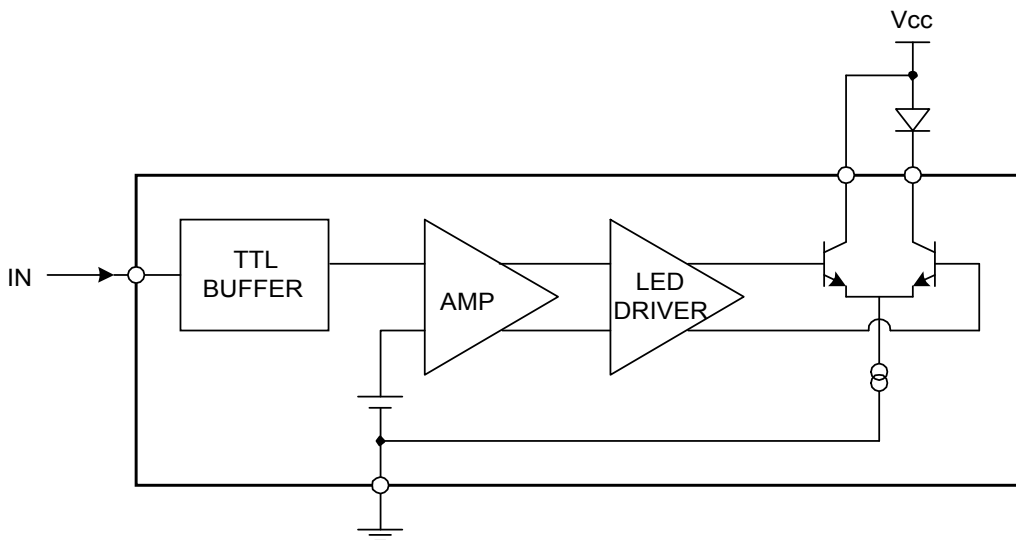

■ Reliability Test Rreport  
Reliability Test(Ta=25°C)

No	Item	Test Condition	Sample (Piece)	Number (n) Failure (c)
1	High temp.operation	Ta=70°C±2°C, Vcc=5V ON, 48h	10	n=10, C=0
2	low temp.operation	Ta=-25°C±2°C, Vcc=5V ON, 48h	10	n=10, C=0
3	Humidity Operrating	Ta=40°C±5°C, 93%RH±3%RH,5VDC, 96h	10	n=10, C=0
4	High temp. storage	Ta=120°C ±2°C, 72h	10	n=10, C=0
5	Low temp. storage	Ta=-30°C±2°C, 72h	10	n=10, C=0
6	High temperature & Humidity. Storage	Ta=85°C±5°C, 93%RH±3%RH, 96h	10	n=10, C=0
7	Temp. cycling	Ta=-25°C(3min)~25→80°C(50min), Ta=80°C(3min)~80→-25°C(50min), 5cycles	10	n=10, C=0
8	Electro Static Discharge	HBM C=100pF, R=1.5kΩ, 4Kv 2 Times/each pins	10	n=10, C=0
9	Solder ability	Ta=260°C±5°C, 5Sec	10	n=10, C=0
10	Repeated Operation Repeat Open/close operation of shutter	After 500 cycles of mating and un-mating, the following value shall be satisfied	10	n=10, C=0
11	Terminal strength(Tension)	Weight: 5N,/10Sec	10	n=10, C=0

If there is any doubt about the results Ambient temperature :5°C~35°C,relative humidity :45%~85%.In the test 1 to 5,10 above the transmitter shall be subjected to standard atmospheric conditions for 2hrs. after which measurement shall be made.

Judgment Criteria

In the testing items of 1-7 and 10 electro-optical characteristics shall be satisfied in following:

Upper specification limit×0.8 or less Lower specification limit×1.2 or more	Upper specification limit ×1.2 or less Lower specification limit ×0.8 or more	Upper specification limit×1.2 or less Lower specification limit×1.2 or
Current consumption (I <sub>CC</sub> ) High Level Input Voltage (V <sub>IL</sub> ) Low Level Input Voltage (V <sub>IH</sub> ) Low to High propagation delay time (t <sub>PLH</sub> ) High to Low propagation delay time (t <sub>PHL</sub> ) Jitter Time (Δ <sub>tj</sub> )	Fiber Coupling Light Output (P <sub>f</sub> )	Pulse Width Distortion (Δ <sub>tw</sub> )

Test No.8 & 9 : Without cracks on the terminal.

Test No.11 : A new uniform coating of solder shall cover a minimum of 75% of the surface be immersed.

Test No.12 : Mating force ≦ 39.2N ; 3.9N ≦ Un-mating force ≦ 39.2N.

■ Reliability Test Rreport-1

Test Item: High temp.operation

Test Condition: Ta=70°C±2°C, Vcc=5V ON , 48h

Test date: 2008.7.25-2008.7.28

Test Item	Pulse Width Distortion	Operating Current	Transmitter Light Power	Jitter	OK	NG
Judgment Criteria	-15ns≤Δtw≤15ns	Iop ≤10mA (mA)	-21dBm≤dBm	Δtj ≤15ns		
No	Before/after	Before/after	Before/after	Before/after		
1	4 / 5	2.53 / 2.56	-17.4 / -17.25	5 / 4	√	
2	2 / 3	2.65 / 2.7	-17.8 / -17.58	6 / 5	√	
3	3 / 4	2.82 / 2.84	-17.64 / -17.48	3 / 3	√	
4	5 / 4	2.84 / 2.87	-17.79 / -18.03	3 / 3	√	
5	6 / 5	2.66 / 2.7	-18.1 / -17.5	4 / 5	√	
6	6 / 5	3.01 / 3.04	-17.63 / -17.5	6 / 4	√	
7	4 / 5	2.78 / 3.04	-18.21 / -18.11	5 / 4	√	
8	4 / 5	2.75 / 2.73	-17.3 / -17.25	6 / 5	√	
9	4 / 4	2.76 / 2.72	-17.8 / -17.63	5 / 3	√	
10	3 / 5	2.85 / 2.90	-17.35 / -17.38	4 / 4	√	

Tester: wangcheng

checker: wangli

approver: jiangyong

■ Reliability Test Rreport-2

Test Item: Low temp.operation

Test Condition: Ta=-25°C±2°C, Vcc=5V ON , 48h

Test date: 2008.7.25-2008.7.28

Test Item	Pulse Width Distortion	Operating Current	Transmitter Light Power	Jitter	OK	NG
Judgment Criteria	-15ns≤Δtw≤15ns	Iop ≤10mA (mA)	-21dBm≤dBm	Δtj ≤15ns		
No	Before/after	Before/after	Before/after	Before/after		
1	5 / 5	3.26 / 3.18	-16.5 / -17.25	4 / 3	√	
2	4 / 3	3.24 / 3.19	-16.92 / -17.58	2 / 3	√	
3	6 / 4	2.85 / 2.84	-16.74 / -17.48	3 / 3	√	
4	5 / 4	2.88 / 2.79	-17.8 / -17.64	3 / 4	√	
5	3 / 5	2.76 / 2.7	-17.4 / -17.52	4 / 5	√	
6	4 / 5	2.89 / 2.95	-16.9 / -17.23	5 / 4	√	
7	5 / 5	2.92 / 3.04	-16.58 / -17.13	3 / 4	√	
8	4 / 5	2.93 / 2.73	-17.3 / -17.25	4 / 5	√	
9	4 / 4	2.77 / 2.72	17.28 / -17.63	2 / 3	√	
10	6 / 5	2.85 / 2.90	-17.45 / -17.38	4 / 5	√	

Tester: wangcheng

checker: wangli

approver: jiangyong

■ Reliability Test Rreport-3

Test Item: Humidity Operrating

Test Condition: Ta=40°C±5°C, 93%RH±3%RH,5VDC, 96h

Test date: 2008.7.25-2008.7.28

Test Item	Pulse Width Distortion	Operating Current	Transmitter Light Power	Jitter	OK	NG
Judgment Criteria	-15ns≤Δtw≤15ns	Iop ≤10mA (mA)	-21dBm≤dBm	Δtj ≤15ns		
No	Before/after	Before/after	Before/after	Before/after		
1	3 / 4	3.26 / 3.33	-16.5 / -17.25	4 / 4	√	
2	4 / 3	3.02 / 3.19	-16.92 / -17.58	5 / 3	√	
3	2 / 3	2.79 / 2.84	-16.74 / -17.48	5 / 3	√	
4	3 / 4	2.98 / 2.87	-17.8 / -17.64	6 / 4	√	
5	4 / 5	2.86 / 2.87	-17.4 / -17.52	4 / 3	√	
6	3 / 4	2.69/ 2.65	-16.9 / -17.23	6 / 3	√	
7	4/ 5	2.92 / 2.87	-16.58 / -17.13	6 / 6	√	
8	2 / 3	2.83 / 2.79	-17.3 / -17.25	3 / 4	√	
9	3 / 4	2.65 / 2.72	17.28 / -17.63	4 / 4	√	
10	5 / 4	2.77 / 2.79	-17.45 / -17.38	6 / 5	√	

Tester: wangcheng

checker: wangli

approver: jiangyong

■ Reliability Test Rreport-4

Test Item: High temp. storage

Test Condition: Ta=120°C ±2°C ,72h

Test date: 2008.7.30-2008.8.4

Test Item	Pulse Width Distortion	Operating Current	Transmitter Light Power	Jitter	OK	NG
Judgment Criteria	-15ns≤Δtw≤15ns	Iop ≤10mA (mA)	-21dBm≤dBm	Δtj ≤15ns		
No	Before/after	Before/after	Before/after	Before/after		
1	2 / 3	2.89 / 2.84	-16.8 / -17.25	4 / 4	√	
2	3 / 3	2.75 / 2.72	-17.52 / -17.38	3 / 3	√	
3	2 / 4	2.79 / 2.74	-16.89 / -17.48	5 / 4	√	
4	3 / 3	2.89/ 2.83	-17.38 / -17.35	3 / 4	√	
5	5 / 3	2.83 / 2.81	-17.64 / -17.52	5 / 3	√	
6	3 / 3	2.79/ 2.75	-16.69 / -16.83	4 / 5	√	
7	3 / 4	2.62 / 2.68	-16.55 / -16.43	3 / 5	√	
8	1 / 3	2.87/ 2.82	-17.23 / -17.28	6 / 4	√	
9	4 / 3	2.65 / 2.64	17.28 / -17.63	3 / 3	√	
10	3 / 4	2.86/ 2.83	-17.15 / -17.28	4 / 3	√	

Tester: wangcheng

checker: wangli

approver: jiangyong

■ Reliability Test Rreport-5

Test Item: Low temp. storage  
 Test Condition: Ta=-30°C±2°C, 72h  
 Test date: 2008.7.30-2008.8.4

Test Item	Pulse Width Distortion	Operating Current	Transmitter Light Power	Jitter	OK	NG
Judgment Criteria	-15ns≤Δtw≤15ns	Iop ≤10mA (mA)	-21dBm≤dBm	Δtj ≤15ns		
No	Before/after	Before/after	Before/after	Before/after		
1	4 / 5	2.75 / 2.79	-17.58/-17.31	5 / 4	√	
2	4 / 6	2.66 / 2.72	-17.78/-17.28	4 / 3	√	
3	3 / 4	2.73 / 2.76	-17.51/-17.24	5 / 6	√	
4	4 / 6	2.69/ 2.63	-18.00/-17.46	3 / 4	√	
5	4 / 5	2.93 / 2.99	-17.76/-17.41	4 / 4	√	
6	5 / 6	3.01 / 3.08	-18.17/-17.87	4 / 5	√	
7	3 / 4	2.72 / 2.68	-17.91/-18.08	2 / 3	√	
8	5 / 5	3.10 / 3.05	-17.34/-17.66	3 / 3	√	
9	2 / 4	2.65 / 2.69	-18.21/-18.06	3 / 4	√	
10	4 / 5	2.86 / 2.91	-17.09/-17.36	4 / 3	√	

Tester: wangcheng      checker: wangli      approver: jiangyong

■ Reliability Test Rreport-6

Test Item: High temperature & Humidity. Storage  
 Test Condition: Ta=85°C±5°C, 93%RH±3%RH, 96h  
 Test date: 2008.7.30-2008.8.4

Test Item	Pulse Width Distortion	Operating Current	Transmitter Light Power	Jitter	OK	NG
Judgment Criteria	-15ns≤Δtw≤15ns	Iop ≤10mA (mA)	-21dBm≤dBm	Δtj ≤15ns		
No	Before/after	Before/after	Before/after	Before/after		
1	3 / 5	2.85 / 2.87	-17.40/-17.25	4 / 4	√	
2	5 / 4	2.76 / 2.79	-17.80/-17.58	5 / 3	√	
3	6 / 5	2.83 / 2.79	-17.64/-17.39	5 / 3	√	
4	4 / 3	2.77/ 2.80	-17.79/-17.48	6 / 4	√	
5	3 / 4	2.79 / 2.80	-18.10/-18.03	4 / 3	√	
6	5 / 4	2.95 / 3.01	-17.63/-17.50	6 / 5	√	
7	4 / 5	2.72 / 2.68	-18.21/-18.11	6 / 6	√	
8	6 / 4	2.88 / 2.93	-17.30/-17.25	3 / 4	√	
9	5 / 3	2.67 / 2.69	-17.80/-17.63	4 / 4	√	
10	4 / 4	2.76 / 2.85	-17.35/-17.20	5 / 5	√	

Tester: wangcheng      checker: wangli      approver: jiangyong

■ Reliability Test Rreport-7

Test Item: Temp. cycling

Test Condition: Ta=-25°C(3min)~25→80°C(50min)→Ta=80°C(3min)~80→-25°C(50min), 5cycles

Test date: 2008.7.30-2008.8.4

Test Item	Pulse Width Distortion	Operating Current	Transmitter Light Power	Jitter	OK	NG
Judgment Criteria	-15ns≤Δtw≤15ns	Iop ≤10mA (mA)	-21dBm≤dBm	Δtj ≤15ns		
No	Before/after	Before/after	Before/after	Before/after		
1	3 / 5	2.85 / 2.87	-17.40/-17.25	4 / 4	√	
2	5 / 4	2.76 / 2.79	-17.80/-17.58	5 / 3	√	
3	6 / 5	2.83 / 2.79	-17.64/-17.39	5 / 3	√	
4	4 / 3	2.77/ 2.80	-17.79/-17.48	6 / 4	√	
5	3 / 4	2.79 / 2.80	-18.10/-18.03	4 / 3	√	
6	5 / 4	2.95 / 3.01	-17.63/-17.50	6 / 5	√	
7	4 / 5	2.72 / 2.68	-18.21/-18.11	6 / 6	√	
8	6 / 4	2.88 / 2.93	-17.30/-17.25	3 / 4	√	
9	5 / 3	2.67 / 2.69	-17.80/-17.63	4 / 4	√	
10	4 / 4	2.76 / 2.85	-17.35/-17.20	5 / 5	√	

Tester: wangcheng

checker: wangli

approver: jiangyong

■ Reliability Test Rreport-8

Test Item: Electro Static Discharge

Test Condition: HBM C=100pF, R=1.5kΩ, 4Kv, 2 Times/each pins

Test date: 2008.8.10-2008.8.11

Test Item	Pulse Width Distortion	Operating Current	Transmitter Light Power	Jitter	OK	NG
Judgment Criteria	-15ns≤Δtw≤15ns	Iop ≤10mA (mA)	-21dBm≤dBm	Δtj ≤15ns		
No	Before/after	Before/after	Before/after	Before/after		
1	4 / 5	2.93 / 2.87	-17.80 /-17.28	5 / 4	√	
2	3 / 4	2.96 / 2.91	-16.21 /-16.30	4 / 3	√	
3	5 / 4	2.73 / 2.75	-17.84 /-17.55	4 / 5	√	
4	4 / 5	2.77/ 2.83	-17.59 /-17.78	5 / 3	√	
5	3 / 5	2.89 / 2.85	-16.03 /-16.25	4 / 3	√	
6	5 / 4	2.97 / 2.89	-17.43 /-17.72	5 / 4	√	
7	4 / 5	2.69 / 2.64	-16.35 /-16.44	3 / 4	√	
8	3 / 2	2.81 / 2.83	-17.30 /-17.63	3 / 5	√	
9	3 / 4	2.69 / 2.72	-17.32 /-17.38	4 / 5	√	
10	3 / 3	2.73 / 2.77	-17.65 /-17.32	4 / 3	√	

Tester: wangcheng

checker: wangli

approver: jiangyong

■ Reliability Test Rreport-9

Test Item: Solder ability

Test Condition: Ta=260°C±5°C, 5Sec

Test date: 2008.8.11-2008.8.12

Test Item	Pulse Width Distortion	Operating Current	Transmitter Light Power	Jitter	OK	NG
Judgment Criteria	-15ns≤Δtw≤15ns	Iop ≤10mA (mA)	-21dBm≤dBm	Δtj ≤15ns		
No	Before/after	Before/after	Before/after	Before/after		
1	2 / 3	2.78 / 2.76	-17.62/-17.35	4 / 3	√	
2	3 / 4	2.86 / 2.84	-16.32/-16.53	2 / 3	√	
3	4 / 5	2.89 / 2.85	-16.35/-16.48	5 / 3	√	
4	4 / 5	2.78 / 2.79	-16.65/-16.45	3 / 4	√	
5	4 / 5	2.93 / 2.87	-17.13/-17.56	4 / 3	√	
6	3 / 5	2.86 / 2.84	-16.13/-16.59	5 / 4	√	
7	4 / 3	2.69 / 2.74	-17.37/-18.12	3 / 3	√	
8	4 / 5	2.85 / 2.89	-16.46/-16.35	4 / 5	√	
9	5 / 4	2.75 / 2.72	-17.61/-17.30	4 / 3	√	
10	4 / 5	2.78 / 2.72	-16.31/-16.46	3 / 4	√	

Tester: wangcheng

checker: wangli

approver: jiangyong

■ Reliability Test Rreport-10

Test Item: Solder Ability

Test Condition: Ta=260°C, 5Sec used as rosin flux

Test date: 2008.8.16-2008.8.17

Test Item	Minmum of 75% of The Surface being immersed			OK	NG
No	PIN1	PIN2	PIN3		
1	OK	OK	OK	√	
2	OK	OK	OK	√	
3	OK	OK	OK	√	
4	OK	OK	OK	√	
5	OK	OK	OK	√	
6	OK	OK	OK	√	
7	OK	OK	OK	√	
8	OK	OK	OK	√	
9	OK	OK	OK	√	
10	OK	OK	OK	√	

Tester: wangcheng

checker: wangli

approver: jiangyon

■ Reliability Test Rreport-11

Test Item: 1.Repeate operation

2.Repeat Open/close operation of shutter

Test Condition: T After 500 cycles of mating and un-mating.

Test date: 2008.8.17-2008.8.18

Test Item No	Before		After 500Times		OK	NG
	Insertion Force (N)	Withdrawal Force (N)	Insertion Force (N)	Withdrawal Force (N)		
1	11.3	10.4	10.5	9.5	√	
2	10.8	9.7	9.3	8.9	√	
3	9.5	10.8	9.1	9.3	√	
4	11.4	12.7	10.5	11.4	√	
5	9.2	11.2	8.7	10.6	√	
6	10.4	10.9	9.6	10.2	√	
7	12.2	11.5	11.3	10.4	√	
8	11.9	11.8	10.8	11.2	√	
9	10.5	10.8	9.7	9.7	√	
10	12.6	11.2	11.5	11.3	√	

Tester: wangcheng

checker: wangli

approver: jiangyon

■ PRECAUTIONS DURING USE

**1) Maximum rating**

The maximum ratings are the limit values that must not be exceeded when using the device. Any one of the ratings must not be exceeded. If the maximum rating is exceeded, the characteristics may not be recovered. In some extreme cases, the device may be permanently damage.

**2) Life of light emitters**

When the optical module is used for over a long period, degeneration of characteristics is mostly due to lowering of the fiber output power (Pf). This is caused by the degradation of the optical output of the LED's used as the light source. The cause of degradation of the optical output of the LED's may be defects in wafer crystallization or mold resin stress. The detailed caused are, however, not clear.

The life of light emitters is greatly influenced by operating conditions and usage environment as well as the life characteristics unique to the device. Thus, when selecting a light emitter and setting the operating conditions, GOOD TAKE recommends that you check the life characteristics.

Depending on the environment conditions, GOOD TAKE recommends maintenance such as regular checks on the amount of optical output.



### 3) Soldering

Optical modules use semiconductor devices internally. However, in principle, optical modules are optical components. At soldering, take care that flux does not contact the emitting surface or detecting surface. Also take care at flux removal after soldering. Some optical modules come with protective cap. The protective cap is used to avoid malfunction when the optical module is not in use. Note that it is not dust or waterproof.

As mentioned before, optical modules are optical components. Thus, in principle, soldering where there may be flux residue or flux removal after soldering is not recommended. GOOD TAKE recommends that soldering be performed without the optical module mounted on the board. Then, after the board is cleaned, solder the optical module manually. Do not perform any further cleaning. If the optical module cannot be soldered manually, use non-halogen (chlorine-free) flux and make sure, without cleaning, there is no residue such as chlorine. This is one of the ways to eliminate the effects of flux. In such a case, check the reliability.

### 4) Vibration and shock

This module is resin-molded construction with wire fixed by resin. This structure is relatively sound against vibration or shock. In actual equipment, there are some cases where vibration, shock, and stress is applied to soldered parts or connected parts, resulting in line cut. Attention must be paid to the design of the mechanism for applications that are subject to large amounts of vibration.

### 5) Fixing fiber optical transmitting module

Solder the fixed pin of fiber optic transmitting module HKTX179W12 to the printed circuit board to fix the module to the board.

### 6) Solvent

When using solvent for flux removal, do not use a high acid or high alkali solvent. Be careful not to pour solvent in the optical connector ports. If solvent is inadvertently poured there, clean with cotton tips.

### 7) Supply voltage

Use the supply voltage within the Typ. Operating condition ( $V_{cc} = 2.7V \sim 5.5V$ ). Make sure that supply voltage does not exceed the maximum rating value of 7V, even instantaneously.

### 8) Input voltage

If a voltage exceeding the maximum rating value ( $V_{cc} + 0.5V$ ) is applied to the transmitter Input, the internal IC may degrade causing some damage. If excessive voltage due to surge may be added to the input, insert a protective circuit.

### 9) Soldering condition

Solder at 260 °C or less within ten seconds.

### 10) Precaution on waste

When discarding devices and packing materials, follow procedures stipulated by local regulations in order to protect the environment against contamination.

Compound semiconductors such as GaAs are used as LED materials for this module. When discarding waste or at final processing, attention must be paid to workers and the environment.

**11) Precaution on use**

GOOD TAKE is continually working to improve the quality and the reliability of its products. Nevertheless, semiconductor devices in general can malfunction or fail due to their inherent electrical sensitivity and vulnerability to physical stress. It is the responsibility of the buyer, when utilizing GOOD TAKE products, to observe standards of safety, and to avoid situations in which a malfunction or failure of a GOOD TAKE product could cause loss of human life, bodily injury or damage to property. In developing your designs, please ensure that GOOD TAKE products are used within specified operating ranges as set forth in the most recent product specifications.

