

**AT442-ALS-T1**

**DATA SHEET**

REV. : 1.0

DATE : 20-Apr.-2005

## Ambient Light Sensor, RoHS Compliant, Released for Lead (Pb)-free Solder Process

### Description

AT442-ALS-T1 ambient light sensor plays a key role in power savings strategies by controlling LCD display intensity and keypad backlighting of mobile devices and in industrial on/off-lighting operation. It is sensitive to visible light much like the human eye and has peak sensitivity at 580 nm. AT442-ALS-T1 has analog output and is packaged in a small surface mount package.

### Features

- Product designed and qualified acc. AEC-Q101 for the automotive market
- High sensitivity,  $I_{PCE} = 40 \mu A$  ( $E_V = 100 \text{ lx}$ )
- Adapted to human eye responsivity
- Wide angle of half sensitivity  $\varphi = \pm 60^\circ$
- Surface mount package
- Dimensions: L 4 mm x W 2 mm x H 1.05 mm
- Lead (Pb)-free soldering released
- Lead (Pb)-free component in accordance with RoHS 2002/95/EC and WEEE 2002/96/EC

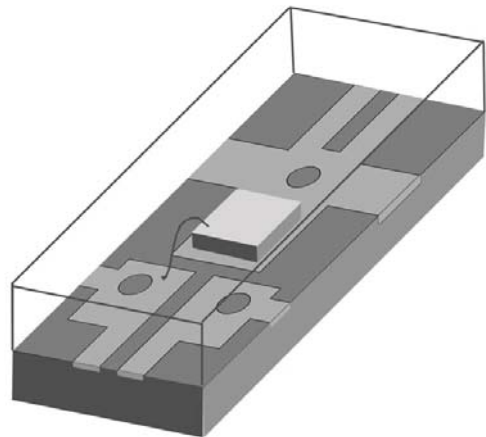

### Applications

Ambient light sensor for control of display backlight dimming in LCD displays and keypad backlighting of mobile devices and in industrial on/off-lighting operation.

- Automotive sensors
- Mobile phones
- Notebook computers
- PDA's
- Cameras
- Dashboards

**Absolute Maximum Ratings**

$T_{amb} = 25\text{ }^{\circ}\text{C}$ , unless otherwise specified

Parameter	Test condition Symbol	Symbol	Value	Unit
Collector emitter voltage		$V_{CEO}$	6	V
Emitter collector voltage		$V_{ECO}$	1.5	V
Collector current		$I_C$	20	mA
Total power dissipation	$T_{amb} \leq 55\text{ }^{\circ}\text{C}$	$P_{tot}$	100	mW
Junction temperature		$T_j$	100	$^{\circ}\text{C}$
Operating temperature range		$T_{amb}$	- 40 to + 100	$^{\circ}\text{C}$
Storage temperature range		$T_{stg}$	-40 to + 100	$^{\circ}\text{C}$
Soldering temperature	Reflow Profile Figure 7	$T_{sd}$	260	$^{\circ}\text{C}$
Thermal resistance junction/ambient		$R_{thJA}$	450	K/W

**Basic Characteristics**

$T_{amb} = 25\text{ }^{\circ}\text{C}$ , unless otherwise specified

Parameter	Test condition	Symbol	Min	Typ	Max	Unit
Collector emitter breakdown voltage	$I_C = 0.1\text{ mA}$	$V_{CEO}$	15			V
Collector dark current	$V_{CE} = 5\text{ V}$ , $E = 0\text{ lx}$	$I_{CEO}$		3	50	nA
Collector-emitter capacitance	$V_{CE} = 0\text{ V}$ , $f = 1\text{ MHz}$ , $E_V = 0$	$C_{CEO}$		16		pF
Collector light current	$E_V = 20\text{ lx}$ , CIE illuminant A, $V_{CE} = 5\text{ V}$	$I_{PCE}$	3.5	10	16	$\mu\text{A}$
	$E_V = 100\text{ lx}$ , CIE illuminant A, $V_{CE} = 5\text{ V}$	$I_{PCE}$		40		$\mu\text{A}$
Angle of half sensitivity		$\phi$	$\pm 60$			deg
Wavelength of peak sensitivity		$\lambda_p$		580		nm
Range of spectral bandwidth		$\lambda_{0.1}$		360 to 970		nm
Collector emitter saturation voltage	$E_V = 20\text{ lx}$ , standard light A, $I_{PCE} = 1.2\text{ }\mu\text{A}$	$V_{CEsat}$		0.1		V

Typical Characteristics

Tamb = 25 °C, unless otherwise specified

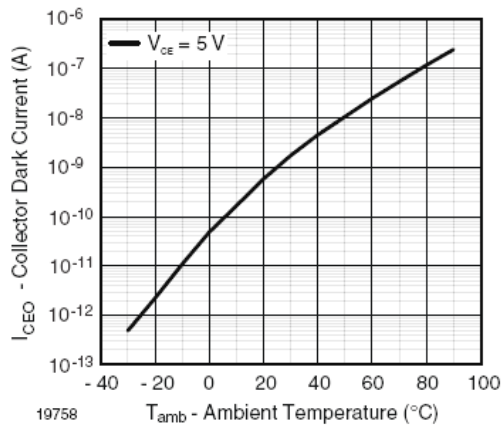

Figure 1. Collector Dark Current vs. Ambient Temperature

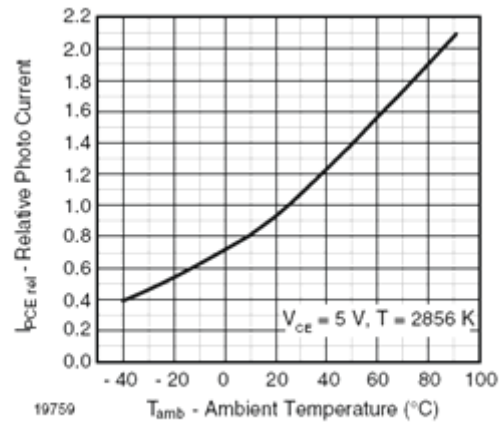

Figure 2. Relative Photo Current vs. Ambient Temperature

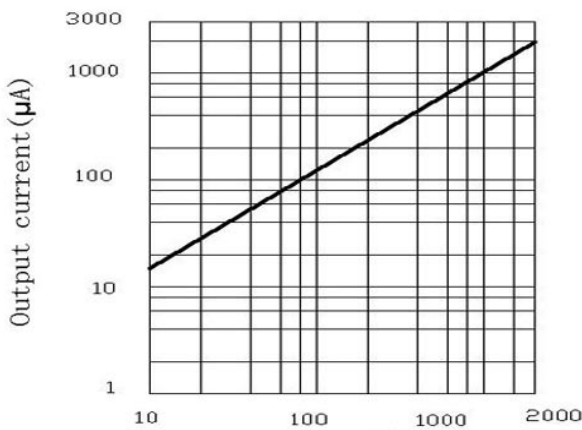

Figure 3 Illuminance (lux)

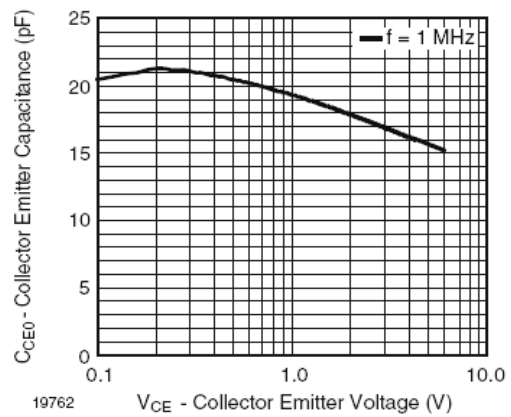

Figure 4. Collector Emitter Capacitance vs. Collector Emitter Voltage

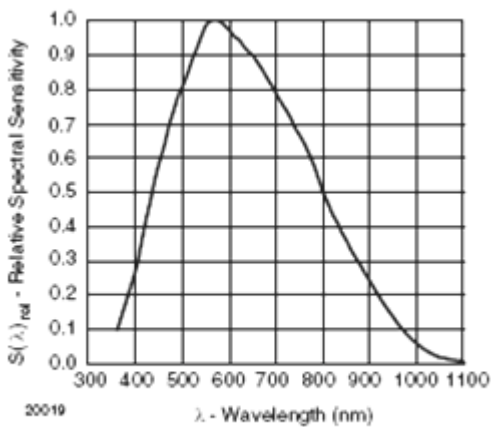

Figure 5. Relative Spectral Sensitivity vs. Wavelength

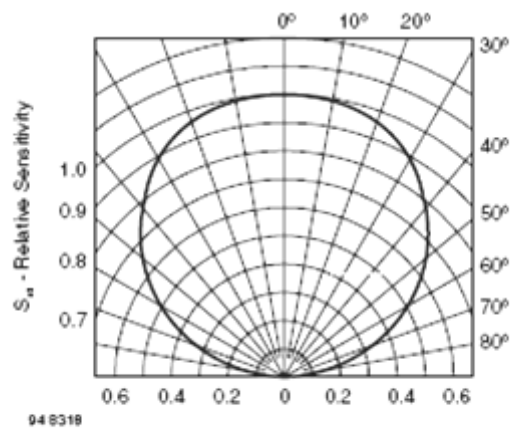

Figure 6. Relative Radiant Sensitivity vs. Angular Displacement

**Drypack**

Devices are packed in moisture barrier bags (MBB) to prevent the products from moisture absorption during transportation and storage. Each bag contains a desiccant.

**Floor Life**

Floor life (time between soldering and removing from MBB) must not exceed the time indicated in J-STD-020 AT442-ALS-A1 is released for: Moisture Sensitivity Level 4, according to JEDEC, J-STD-020

Floor Life: 72 h

Conditions:  $T_{amb} < 30\text{ }^{\circ}\text{C}$ ,  $RH < 60\%$

**Drying**

In case of moisture absorption devices should be baked before soldering. Conditions see J-STD-020 or Label. Devices taped on reel dry using recommended conditions 192 h at  $40\text{ }^{\circ}\text{C}$  (+  $5\text{ }^{\circ}\text{C}$ ),  $RH < 5\%$ .

**Reflow Solder Profiles**

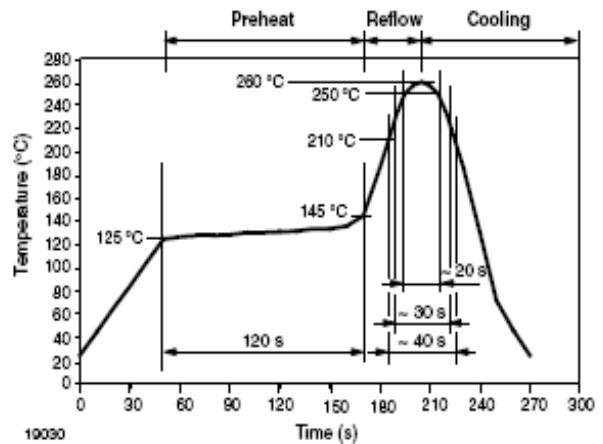

Figure 7. Tin (Sn) Reflow Solder Profile (Pb-free)

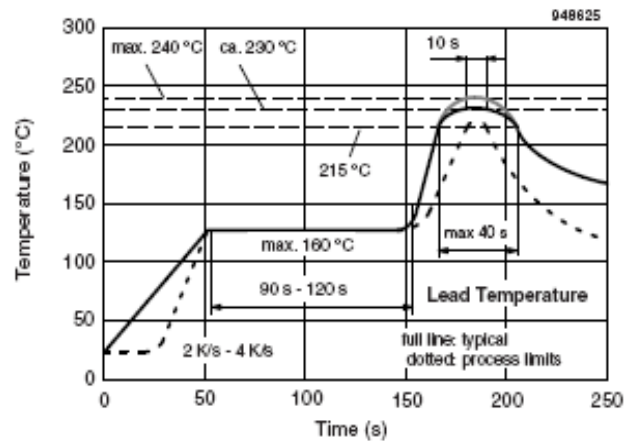
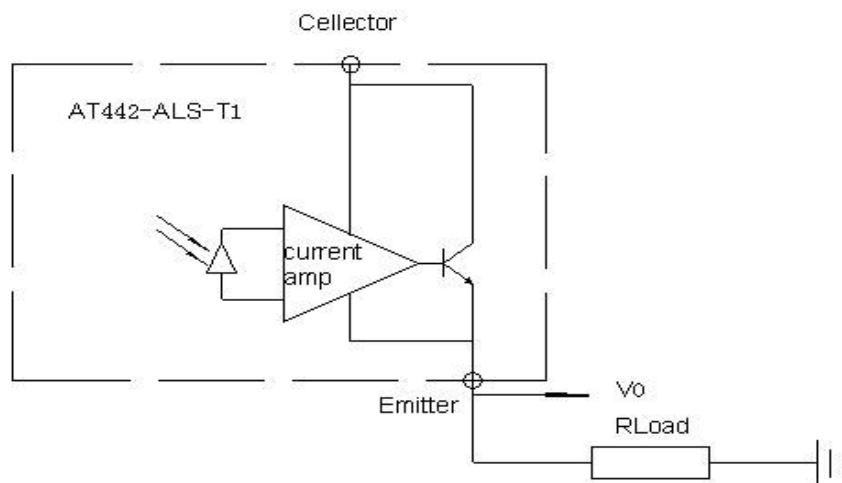
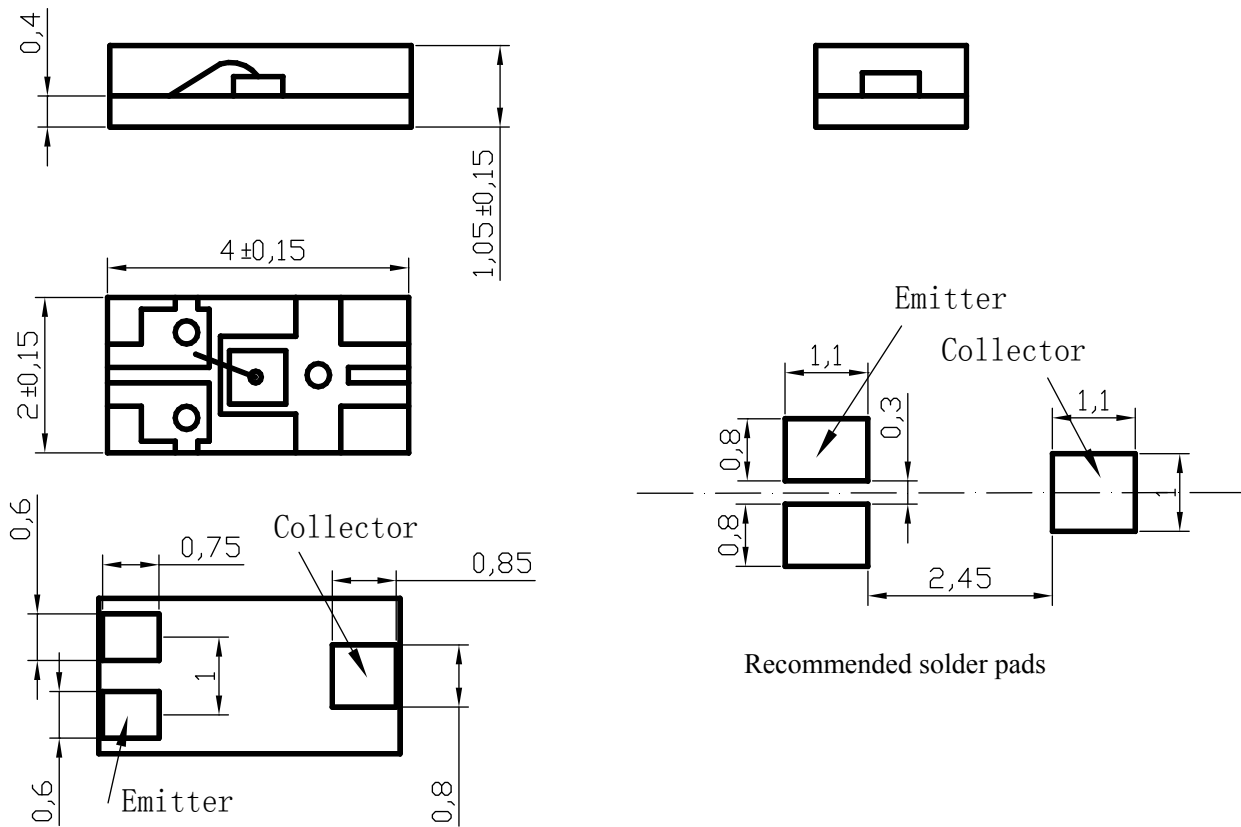

Figure 8. Lead Tin (SnPb) Reflow Solder Profile

**Application circuit**



**Package Dimensions** in millimeters



**Taping Specifications**

(1) Shape and dimensions of reels: unit in mm

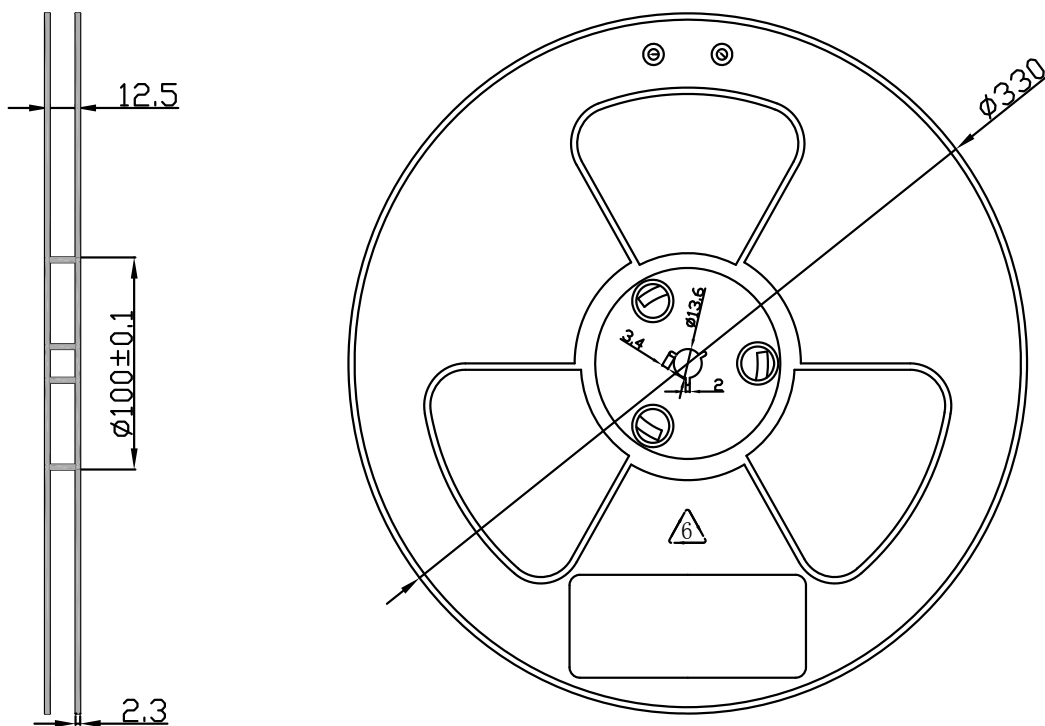



### (3) Configuration of tape

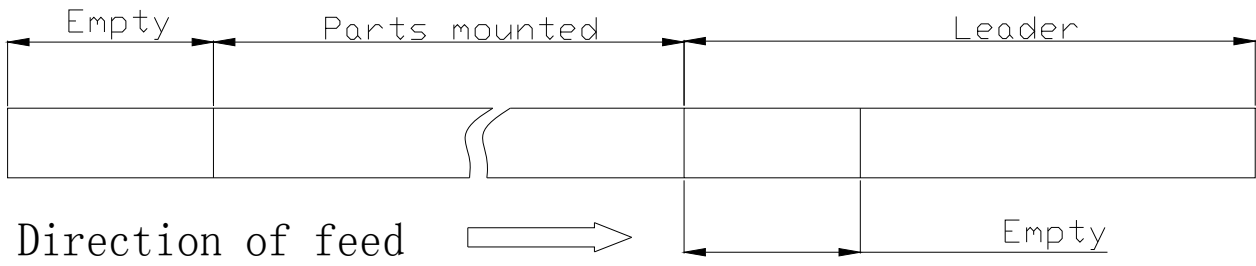

### (4) Quantity: 5000pcs/reel