

FIBER OPTIC RECEIVING NODULE

⑤ FEATURES

1. Conform to EIAJ standard CP-1201 (For Digital audio interfaces including fiber optic inter-connection).
2. A Self-tapping hole for easy attachment to audio equipment panels.
3. +5v single power supply.
4. High-speed signal receiving (6M NRZ signal).
5. ESD tolerance IC > 8KV.
6. Standard package (panel mount type).



⑤ APPLICATIONS

1. Digital audio equipment.
2. Navigation system.

⑤ MAXIMUM RATINGS (Ta=25)

Parameter	Symbol	Rating	Units
Storage Temperature	Tstg	-40~70	
Operating Temperature	Topr	-20~70	
Supply Voltage	V _{CC}	-0.5~7	V
High Level Output Current	I _{OH}	-1	mA
Low Level Output Current	I _{OL}	5	mA
Soldering Temperature	T _{SOI}	260*1	

*1:Soldering time 10 seconds (At a distance of 1mm from the package).

⑤ ORDERING INFORMATION

H K R X 1 7 8 D

R: Receiver T: Transmitter

Housing type A: no window D: Shutter type S: Small type

⑤ RECOMMENDED OPERATING CONDITIONS AND ELECTRICAL CHARACTERISTICS(Ta=25 ,VCC=5V)

Characteristic	Symbol	Condition	Min	Typ	Max	Units
Supply Voltage	V _{CC}		4.75	5.0	5.25	V
Data Rate	T	NRZ Code *1	0.1	-	6	Mb/s
Peak Detective Wavelength	p		-	660	-	nm
Transmission Distance		Using APE *2 Using APTX178	0.2	-	5	m
Pulse Width Distortion*3	tw	Pulse Width=160ns Pulse Cycle=320ns C _L =10Pf Using APTX178	-25	-	25	ns
Maximum Receivable Power	P _{MAX}	6Mb/s, Using APF *2	-14.5	-	-	dBm
Minimum Receivable Power	P _{MIN}	6Mb/s, Using APF *2	-	-	-24	dBm
Current Consumption	I _{cc}	V _{CC} =+5V	-	22	40	mA
High Level output Voltage	V _{OH}		3.6	4.0	-	V
Low Level output Voltage	V _{OL}		-	0.2	0.4	V

*1:When non-modulated signal (optical all high or all low level signal) is inputted, output signal is not stable.

When modulated optical high-level signal is received, output signal is high.

When modulated optical low-level signal is received, output signal is low.

The duty factor must be maintained between 25 to 75%.

*2:APF:All Plastic Fiber(970/1000 μ m), Length 1 Meter.

*3:Between input of transmitting module and output of HKRX178.

⑤ MECHANICAL CHARACTERISTICS(Ta=25)

Characteristic	Symbol	Condition	Min	Typ	Max	Units
Insertion Force		*1	-	-	40	N
Withdrawal Force		*1	6	-	40	N
Torque for Self-Tap		Using self-tapping Screw (M3*8)	60	-	100	N-cm

*1: Using standard optical fiber cable. (970/1000 um)

⑤ APPLICATION CIRCUIT

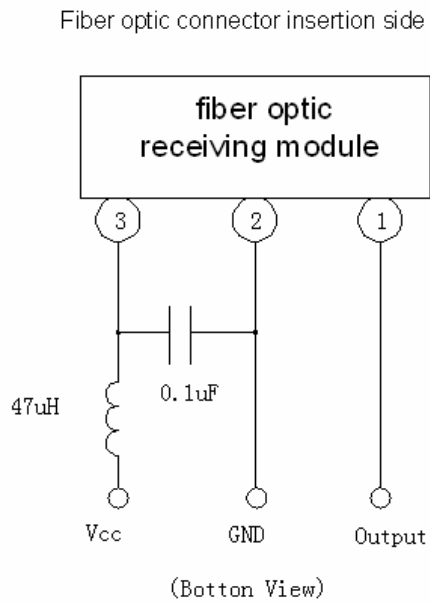

⑤ BLOCK DIAGRAM

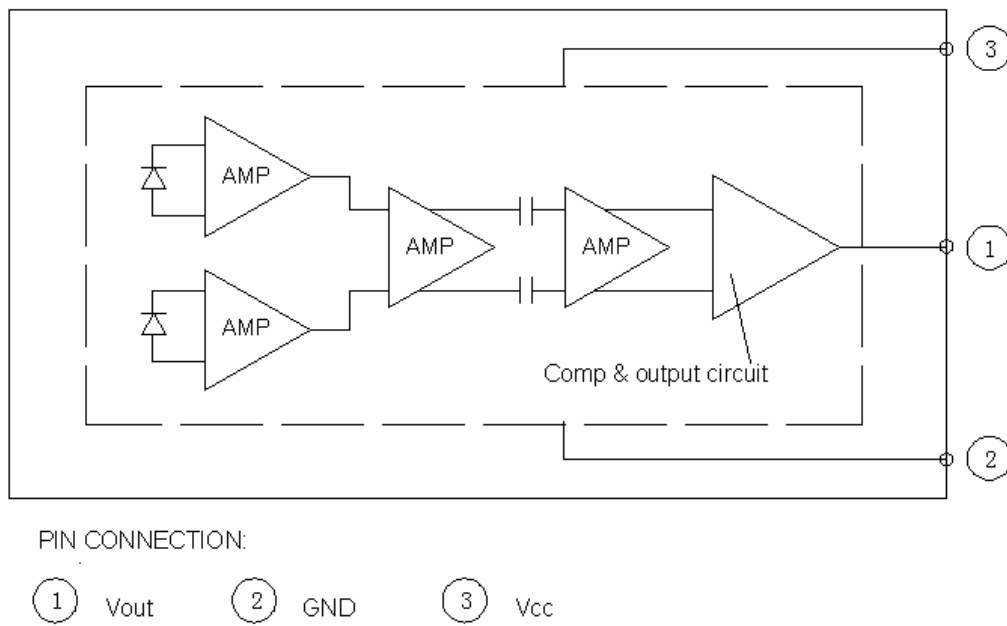

⑤ TEST CIRCUIT

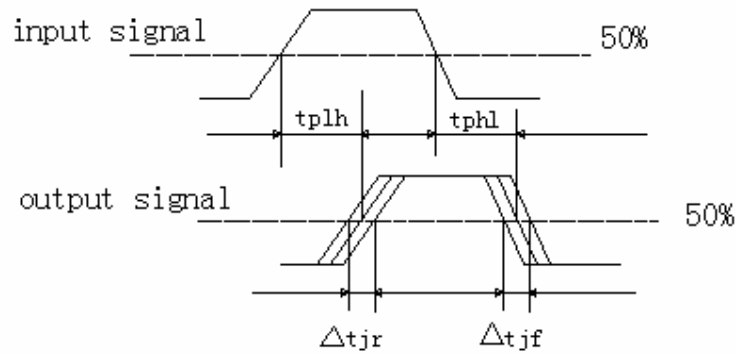
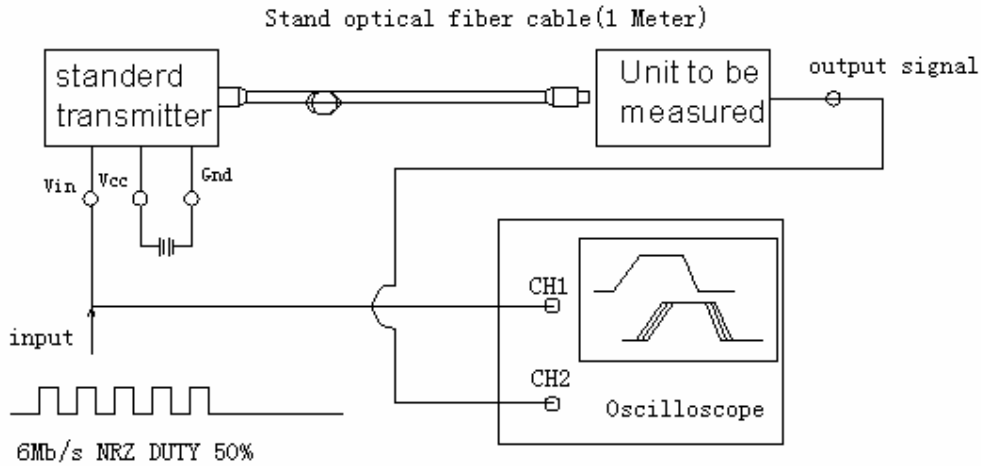

⑤ COMMENTS

No.	Test Item	Symbol
1	Low to High Pulse Delay Time	t_{PLH}
2	High to Low Pulse Delay Ting	t_{PHL}
3	Pulse Width Distortion $tw=t_{PHL} - t_{PLH}$	tw
4	High Level Output Voltage	V_{OH}
5	Low Level Output Voltage	V_{OL}

⑤ HKRX178D

OUTLINE DIMENSION

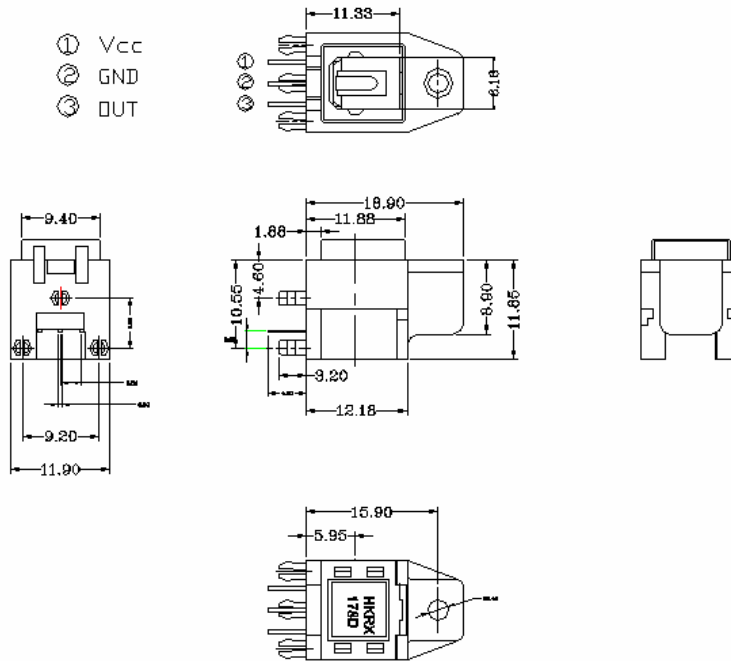

RECOMMENDED DRILING AS VIEWED FROM THE SOLDERING FACE

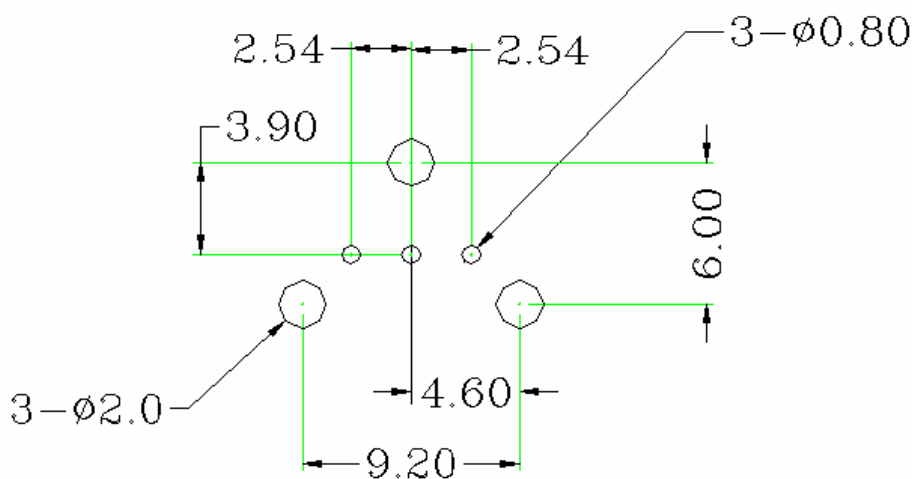

⑤ PRECAUTIONS DURING USE**1) Maximum rating**

The maximum ratings are the limit values that must not be exceeded during operating of device. None of these rating values must not be exceeded, If the maximum rating value is exceeded. The characteristics of devices may never be restored properly. In extreme cases, the device may be permanently damages.

2) Soldering

Optical modules are comprised of internal semiconductor devices. However, in principle, optical modules are Optical components. During soldering, ensure that flux dose not contact with the emitting surface or detecting Surface. Also ensure that proper flux removal is conducted after soldering.

Some optical modules come with protective cap. The protective cap is used to avoid malfunction when the Optical module is not in use. Note that it is not dust or waterproof.

As mentioned before, optical modules are optical components. Thus, in principle, soldering where there may be flux residue or flux removal after soldering is not recommended. Good take recommends that soldering be Performed without the optical module mounted on the board. Then, the board has been cleaned, the Optical module should be soldered on to the board manually.

If the optical module cannot be soldered manually, use non-halogen (chlorine-free) flux and make sure, without cleaning, there is no residue such as chlorine. This is one of the ways to eliminate the effects flux, In such a cases, be sure to check the devices' reliability.

3) Noise resistance

It is believed that use of optical transfer devices improve noise resistance. In theory, optical fiber is not affected by noise at all. However, receiving modules which handle signals whose level is extremely small are susceptible noise.

The optical module is to be used in an area, which is susceptible to radiated noise, increase the shielding by covering the optical module and the power line filter with a metallic cover.

4) Vibration and shock

This module is plastic sealed and has its wire fixed by resin. This structure is relatively resistant to vibration

And shock. In actual equipment, there are sometimes cases in which vibration, shock, and stress is applied

To soldered parts or connected parts, resulting in lines cut. A care must be taken in the design of equipment Which will be subject to high levels of vibration.

5) Support pins

The HKRX178D has support pins in order to fix itself to the PCB temporary. Please make the hole for these pins is the PCB under the condition described in board layout hole pattern.

6) Panel attachment

HKRX178D has hole for panel attachment. Please be sure to attach it to panel with self-tapping screw.

7) Solvent

When using solvent for flux removal, do not use a high acid or high alkali solvent.

Be careful not to pour solvent in the optical connector ports. If solvent is inadvertently poured in to them, clean it off using cotton tips.

8) Protective cap

When the HKRX178D is not in use, attach the protective cap.

9) Supply voltage

Use the supply voltage within the recommended Operating condition ($VCC = 5 \pm 0.25V$). Make sure that supply voltage does not exceed the maximum rating value of 7V, even for an instant.

10) Interface

The HKRX178D has a TTL interface. It can be interfaced with any TTL-compatible C-MOS IC.

11) Output

If the receiver output is at low and is connected to the power supply .or if the output is high and is connected to GND, the internal IC may be destroyed.

12) Soldering condition

Solder at 260 or less for no more than ten seconds.

13) Precautions when disposing of devices and packing materials.

When discarding devices and packing materials, follow the procedures stipulated by local regulations in order to protect the environment against contamination.

14) Precautions during use

Good take is continually working to improve the quality and the reliability of their products. Nevertheless, semiconductor devices in general can malfunction or fail due to their inherent electrical sensitivity and vulnerability to physical stress. It is the responsibility of the buyer, when utilizing Good take products, to observe standards of safety, and to avoid situations in which the malfunction or failure of a Good take product could cause loss of human life, bodily injury or damage to property.