

# Infrared Light Emitting Diode

## 1. GENERAL DESCRIPTION

AT205 is high output power AlGaAs infrared light emitting diode, mounted in clear epoxy package. It emits spectrally narrow band of radiation peaking at 940nm.

## 2. FEATURES

Wide beam angle.

Good linearity.

High output power.

Capable of pulse operation.

Low cost

## 3. ABSOLUTE MAXIMUM RATINGS AT Ta=25

PARAMETER	MAXIMUM RATING	UNIT
Power forward current	150	mW
Peak forward current	1	A
Continuous Forward Current	100	mA
Reverse voltage	5	V
Operating temperature range	-40 to 85	
Storage temperature range	-55 to +85	
Lead soldering temperature	260 for 5 seconds	

## 4. ELECTRICAL OPTICAL CHARACTERISTICS AT Ta=25

PARAMETER	SYMBOL	MIN.	TYP.	MAX.	UNIT	TEST CONDITION
Radiant Intensity	Ee	8	10.2			I <sub>F</sub> =20mA
			45			I <sub>F</sub> =100mA Pulse Width 100 μs, Duty 1%
			450			I <sub>F</sub> =1A Pulse Width 100 μs, Duty 1%.
Peak emission wavelength	λ <sub>peak</sub>		940		nm	I <sub>F</sub> =20mA
Spectral line half-width	Δλ		45		nm	I <sub>F</sub> =20mA
Forward voltage	V <sub>F</sub>		1.2	1.4	V	I <sub>F</sub> =20mA
			1.4	1.5	V	I <sub>F</sub> =100mA Pulse Width 100 μs, Duty 1%
			2.6	4	V	I <sub>F</sub> =1A Pulse Width 100 μs, Duty 1%.
Reverse current	I <sub>R</sub>			10	μA	V <sub>R</sub> =5V
Viewing angle	2θ <sub>1/2</sub>		40		Deg	

**5. TYPICAL ELECTRICAL/OPTICAL CHARACTERISTICS CURVES**

(25 Ambient Temperature Unless Otherwise Noted)

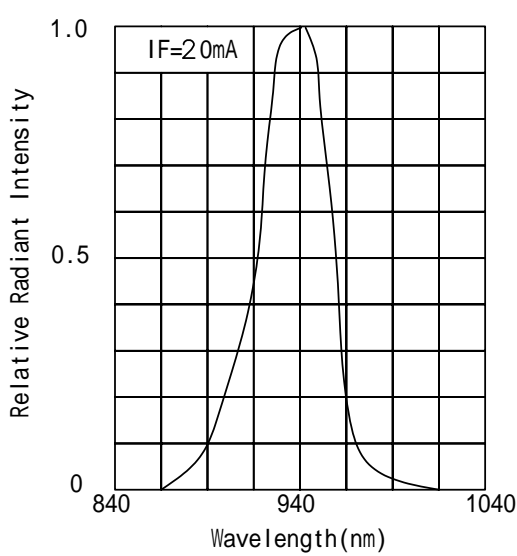

Fig.1 Spectral Distribution

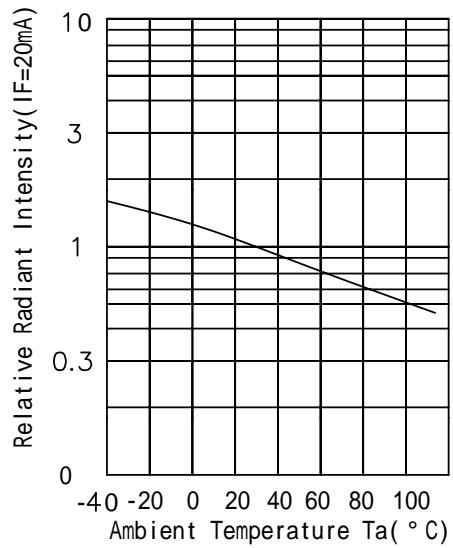

Fig.2 Relative Radiant Intensity Vs Ambient Temperature

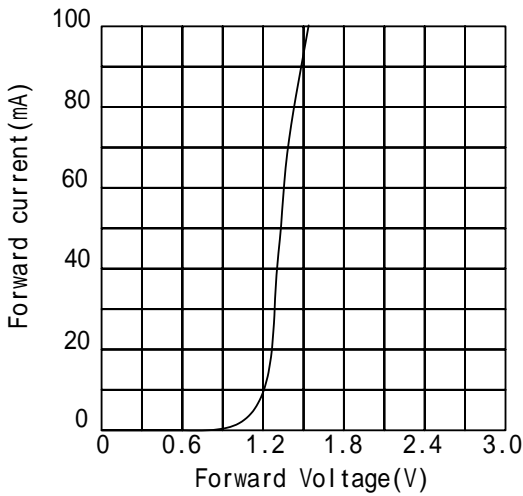

Fig.3 Forward Current Vs Forward Voltage

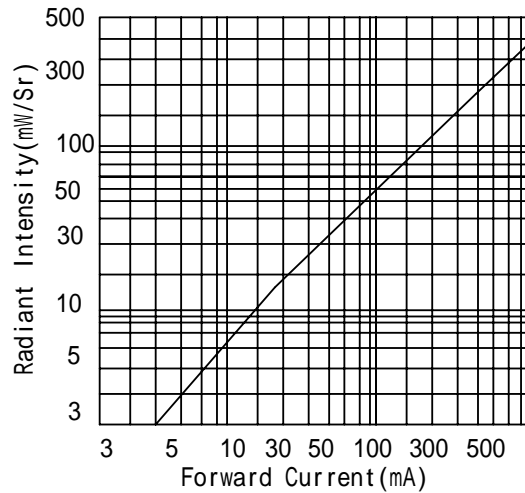

Fig.4 Forward Current Vs Radiant Intensity

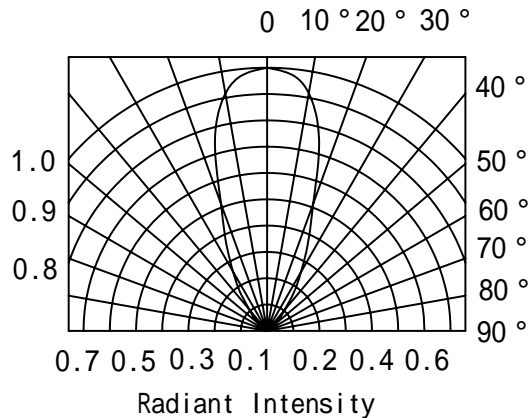
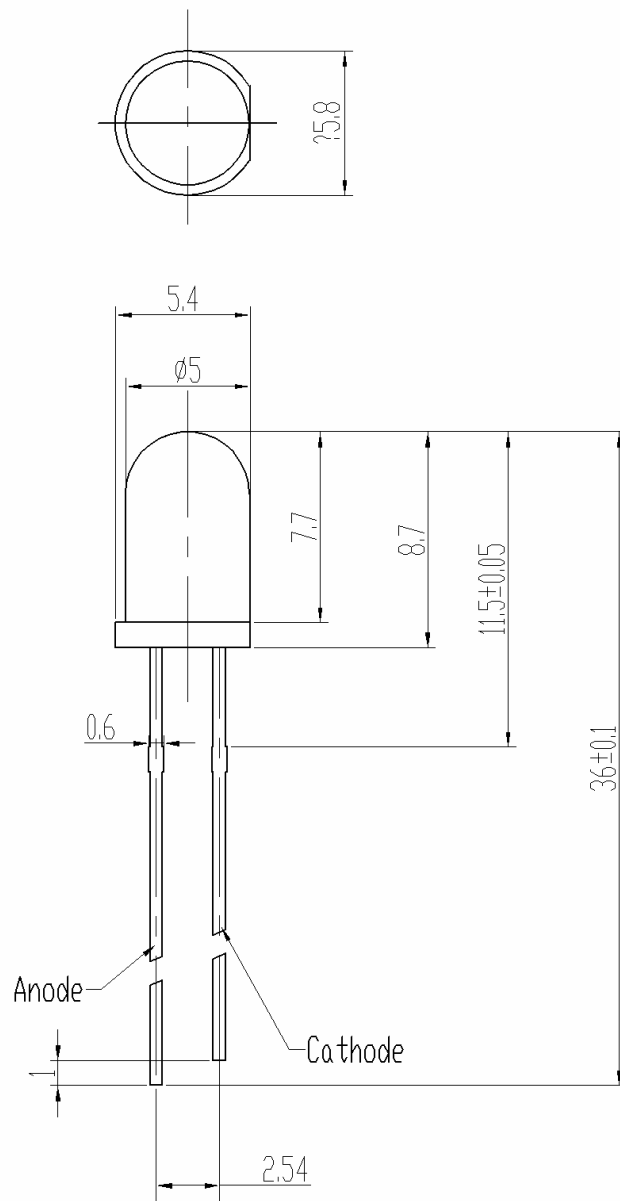

Fig.5 Angle Vs Radiant Intensity

## 6. DIMENSIONS IN MM



### Notes

1. All dimensions are in millimeters.
2. Tolerance is  $\pm 0.2$  unless otherwise noted.
3. An epoxy meniscus may extend about "0.5mm" down the leads.