

AT225-12-80

DATA SHEET

REV. : 1.0

DATE : 20-Apr.-2006

■ FEATURES:

- High reliability.
- High radiant intensity.
- Peak wavelength at 850nm.
- Standard T-1 3/4(φ5MM).
- Lead Free product, in compliance with RoHS. ∅

■ DESCRIPTIONS:

- AT225-12-80 is a high response speed and high radiant intensity infrared emitting diode with exceptionally stable characteristics and high illumination sensitivity.
- Moulded in 5mm diameter and water clear package.

■ APPLICATIONS:

- Free air transmission system.
- Security System.
- Infrared applied system
- Night viewing.

■ DIMENSIONS:

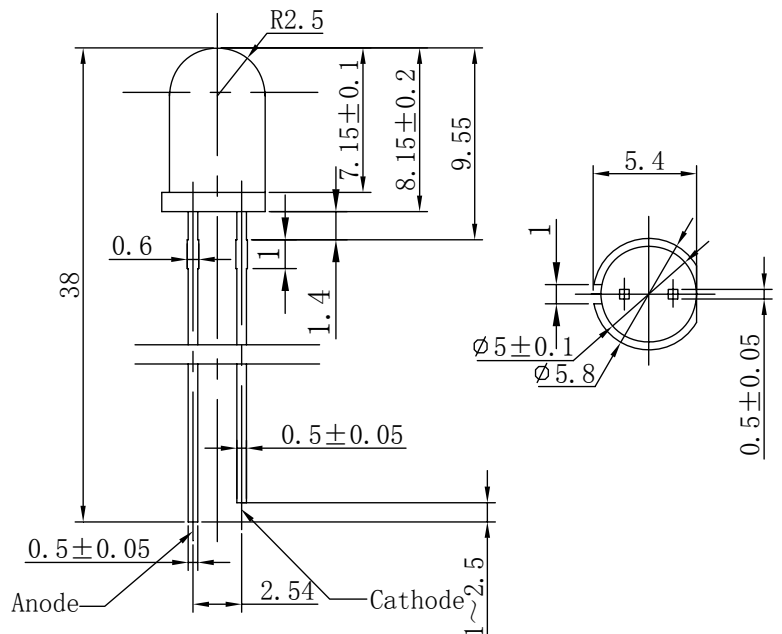

■ INTERNAL CIRCUIT:

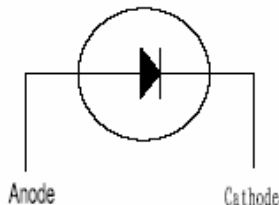

NOTE: 1. All dimensions are in millimeter, tolerance is ± 0.25 unless otherwise noted.
 2. Epoxy meniscus extends ≤ 1 mm down to the lead is allowed.

■ ABSOLUTE MAXIMUM RATINGS AT Ta=25°C

Parameter	Symbol	Ratings	Unit
Power Dissipation	P _D	120	mW
Peak Forward Current	I _{FP}	1	A
Reverse voltage	V _R	5	V
Operating Temperature	T _{opr}	-40~+85	°C
Storage Temperature	T _{stg}	-40~+85	°C
Soldering Temperature	T _{sol}	270°C for 6 sec Max (2mm from Body)	

NOTE: I_{FP} Conditions Pulse Width ≤ 100μs And Duty ≤ 1%.

■ TYPICAL ELECTRICAL & OPTICAL CHARACTERISTICS (Ta=25°C)

Parameter	Symbol	Min.	Type	Max.	Unit	Test Condition
Radiant Intensity	E _e		7		mW/Sr	I _F =20mA
	E _e		35		mW/Sr	I _F =100mA
Forward Voltage	V _F		1.5	1.8	V	I _F =20mA Pulse Width ≤ 100μs Duty ≤ 1%
Reverse Current	I _R			10	μA	V _R =5V
Peak Wavelength	λ _p		850			I _F =20mA
Δλ	T _f		45		nm	I _F =20mA
View Angle	2θ _{1/2}		40		deg	I _F =20mA

■ RELIABILITY TEST ITEMS AND CONDITIONS:

NO	Item	Test Conditions	Test Hours/Cycle	Sample Quantity	Test Result
1	Solder Heat	TEMP: 270°C ± 3°C	10 SEC	11 pcs	0 DEFECT
2	Temperature Cycle	H: +85°C 60min ↑↓ 10min L: -25°C 60min	16 cycles	22 pcs	0 DEFECT
3	Thermal Shock	H: +85°C 30min ↑↓ 30sec L: -25°C 30min	10 cycles	11 pcs	0 DEFECT
4	High Temperature Storage	TEMP: +85°C	1000 HRS	22 pcs	0 DEFECT
5	Low Temperature Storage	TEMP: -25°C	1000 HRS	22 pcs	0 DEFECT
6	High Temperature High Humidity Storage	85°C / 93% RH	1000HRS	22 pcs	0 DEFECT

■ TYPICAL ELECTRO-OPTICAL CHARACTERISTICS CURVES:

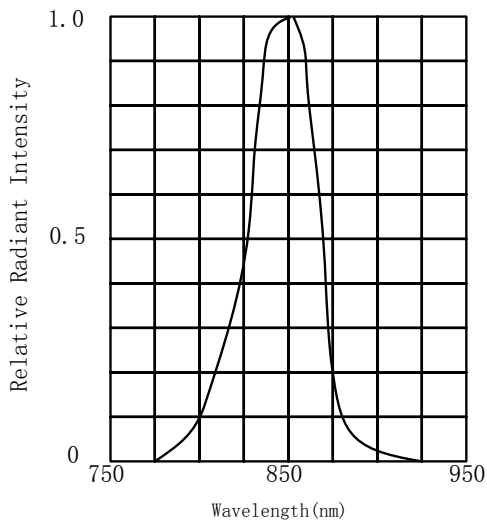

FIG. 1 SPECTRAL DISTRIBUTION

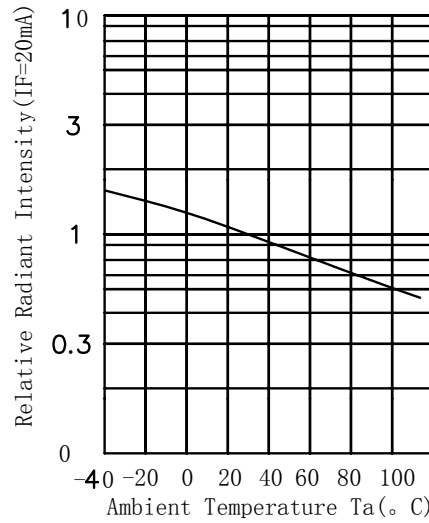

FIG. 2 RELATIVE RADIANT INTENSITY VS AMBIENT TEMPERATURE

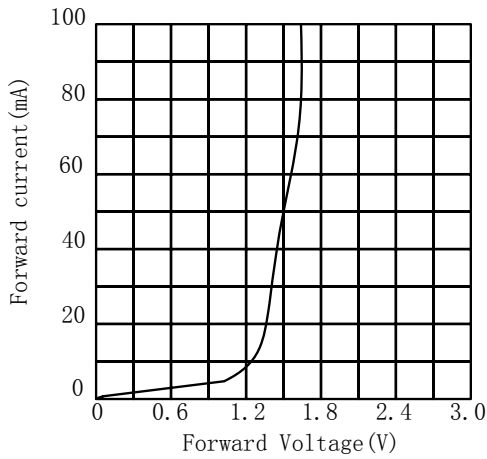

FIG. 3 FORWARD CURRENT VS FORWARD VOLTAGE

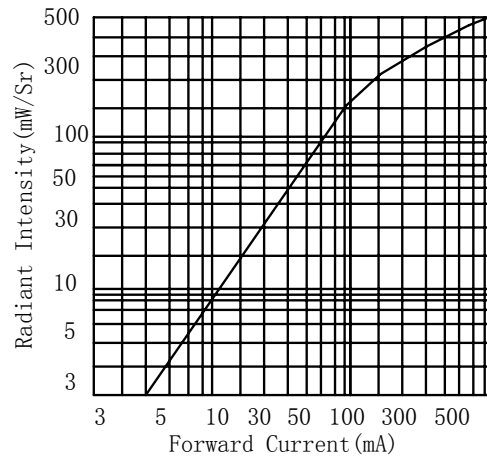

FIG. 4 FORWARD CURRENT VS RADIANT INTENSITY

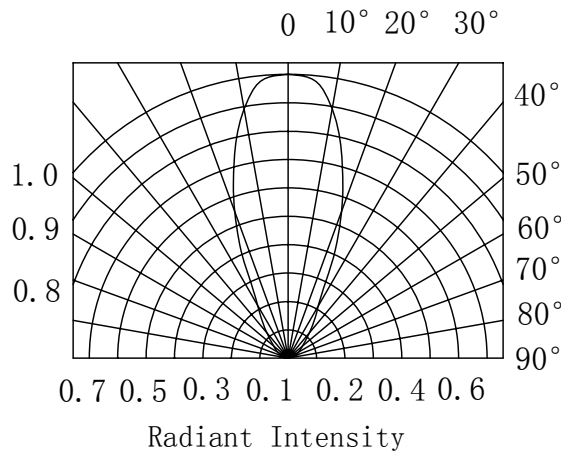

Fig. 5 Angle Vs Radiant Intensity