

**AT228-16-45**

**DATA SHEET**

REV. : 1.0

DATE : 20-Apr.-2006

**■ FEATURES:**

- High reliability.
- High radiant intensity.
- Peak wavelength at 850nm.
- Standard  $\phi 8$ mm.
- Lead Free product, in compliance with RoHS.

**■ DESCRIPTIONS:**

- AT228-16-45 is a high response speed and high radiant intensity infrared emitting diode with exceptionally stable characteristics and high illumination sensitivity.
- Moulded in 8mm diameter and water clear package.

**■ APPLICATIONS:**

- Free air transmission system.
- Security System.
- Infrared applied system
- Night viewing.

**■ DIMENSIONS:**

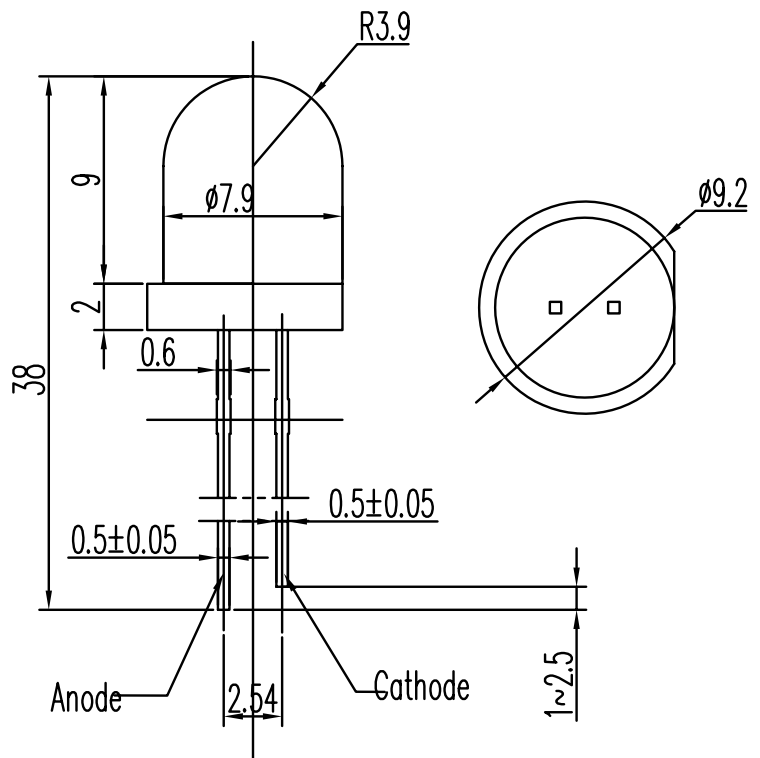

**■ INTERNAL CIRCUIT:**

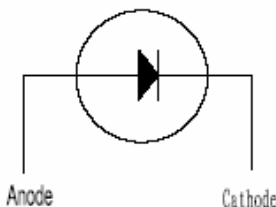

**NOTE :** 1. All dimensions are in millimeter, tolerance is  $\pm 0.25$  unless otherwise noted.  
 2. Epoxy meniscus extends  $\leq 1$  mm down to the lead is allowed.

**■ ABSOLUTE MAXIMUM RATINGS AT Ta=25**



Parameter	Symbol	Ratings	Unit
Continuous Forward Current	I <sub>F</sub>	100	mA
Power Dissipation	P <sub>D</sub>	140	mW
Peak Forward Current	I <sub>FP</sub>	1.3	A
Reverse voltage	V <sub>R</sub>	5	V
Operating Temperature	T <sub>opr</sub>	-40 ~ +85	
Storage Temperature	T <sub>stg</sub>	-40 ~ +85	
Soldering Temperature	T <sub>sol</sub>	270 for 6 sec Max (2mm from Body)	

**NOTE: I<sub>FP</sub> Conditions Pulse Width 100μS And Duty 1%.**

**■ TYPICAL ELECTRICAL & OPTICAL CHARACTERISTICS ( Ta=25 )**

Parameter	Symbol	Min.	Type	Max.	Unit	Test Condition
Radiant Intensity	E <sub>e</sub>		30		mW/sr	I <sub>F</sub> =20mA
			125		mW/sr	I <sub>F</sub> =100mA, t <sub>p</sub> =100 μ s, t <sub>p</sub> /T=0.01
			830		mW/sr	I <sub>F</sub> =1000mA, t <sub>p</sub> =100 μ s, t <sub>p</sub> /T=0.01
Forward Voltage	V <sub>F</sub>		1.4	1.6	V	I <sub>F</sub> =20mA
Reverse Current	I <sub>R</sub>			10	μA	V <sub>R</sub> =5V
Peak Wavelength	λ <sub>p</sub>		850			I <sub>F</sub> =20mA
Spectral Line Half-Width	Δλ		40		nm	I <sub>F</sub> =20mA
View Angle	2θ <sub>1/2</sub>		23		deg	I <sub>F</sub> =20mA

**■ RELIABILITY TEST ITEMS AND CONDITIONS :**

<b>NO</b>	<b>Item</b>	<b>Test Conditions</b>	<b>Test Hours/Cycle</b>	<b>Sample Quantity</b>	<b>Test Result</b>
<b>1</b>	<b>Solder Heat</b>	<b>TEMP : 270 ±3</b>	<b>10 SEC</b>	<b>11 pcs</b>	<b>0 DEFECT</b>
<b>2</b>	<b>Temperature Cycle</b>	<b>H:+85 60min</b>  <b>L:-25 60min</b>	<b>16 cycles</b>	<b>22 pcs</b>	<b>0 DEFECT</b>
<b>3</b>	<b>Thermal Shock</b>	<b>H:+85 30min</b>  <b>L:-25 30min</b>	<b>10 cycles</b>	<b>11 pcs</b>	<b>0 DEFECT</b>
<b>4</b>	<b>High Temperature Storage</b>	<b>TEMP : +85</b>	<b>1000 HRS</b>	<b>22 pcs</b>	<b>0 DEFECT</b>
<b>5</b>	<b>Low Temperature Storage</b>	<b>TEMP : -25</b>	<b>1000 HRS</b>	<b>22 pcs</b>	<b>0 DEFECT</b>
<b>6</b>	<b>High Temperature High Humidity Storage</b>	<b>85 /93% RH</b>	<b>1000HRS</b>	<b>22 pcs</b>	<b>0 DEFECT</b>

■ TYPICAL ELECTRO-OPTICAL CHARACTERISTICS CURVES:

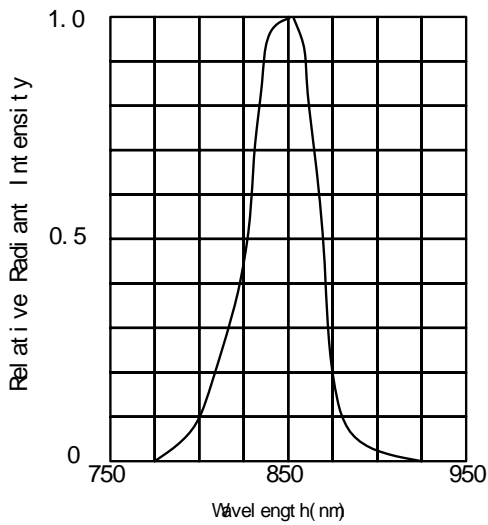

FIG.1 SPECTRAL DISTRIBUTION

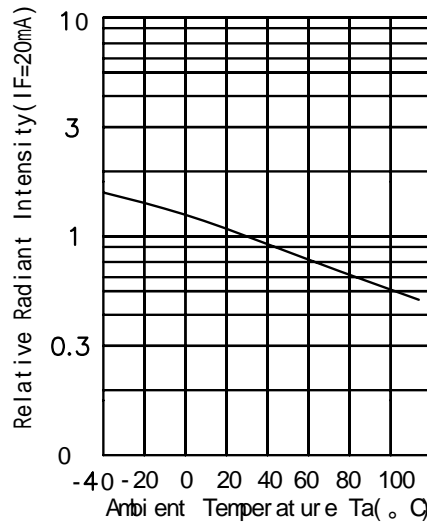

FIG.2 RELATIVE RADIANT INTENSITY VS AMBIENT TEMPERATURE

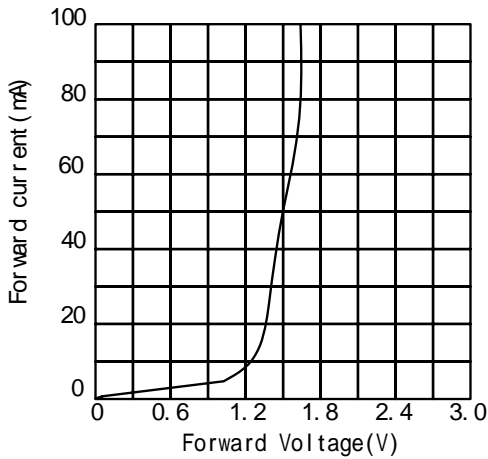

FIG.3 FORWARD CURRENT VS FORWARD VOLTAGE

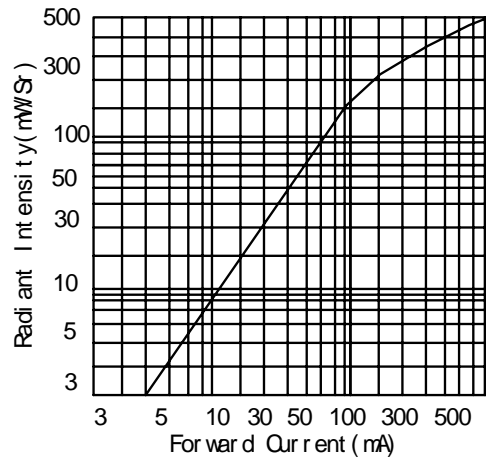

FIG.4 FORWARD CURRENT VS RADIANT INTENSITY

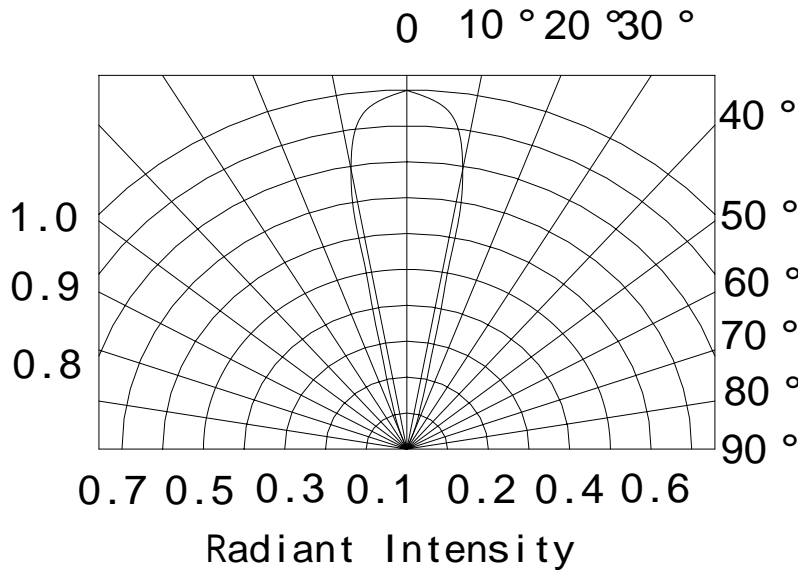

Fig.5 Angle Vs Radiant Intensity