

## Photo Module for PCM Remote Control Systems

### Description

The AT138R is miniaturized receiver for infrared remote control systems. PIN diode and preamplifier are assembled on lead frame, the epoxy package is designed as IR filter.

The demodulated output signal can directly be decoded by a microprocessor. The main benefit is the reliable function even in disturbed ambient and the protection against uncontrolled output pulses.

### Features

- Photo detector and Preamplifier in one package
- Internal filter for PCM frequency
- TTL and CMOS compatibility
- Output active low
- Low power consumption
- Suitable burst length  $\geq 10$  cycles/burst

### Special Features

- Enhanced immunity against all kinds of disturbance light
- No occurrence of disturbance pulses at the output

### Block Diagram

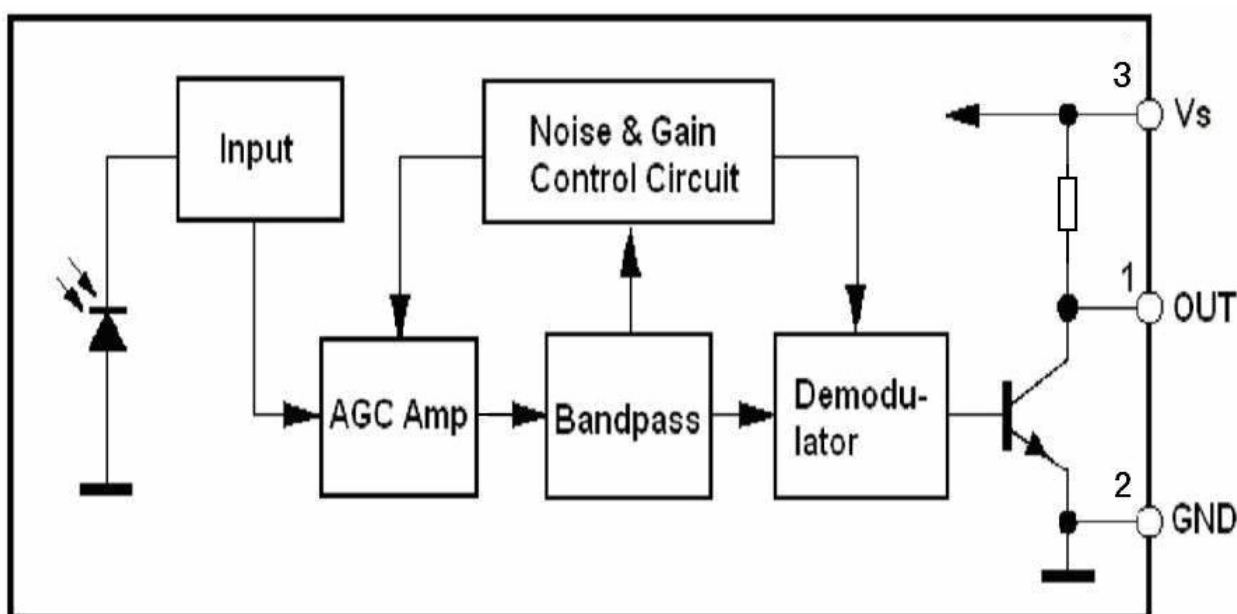

A

## Absolute Maximum Ratings

Tamb = 25

Parameter	Test Conditions	Symbol	Value	Unit
Supply Voltage	(Pin 3)	Vs	6.0	V
Supply Current	(Pin 3)	Is	5	mA
Output Voltage	(Pin 1)	Vo	6.0	V
Storage Temperature Range		Tstg	-30...+105	
Operating Temperature Range		Tamb	-25...+85	
Power Consumption	(Tamb = 85 °C)	ptot	50	mW
Soldering Temperature	t = 5s	Tsd	260	

## Basic Characteristics

Tamb = 25

Parameter	Test Conditions	Symbol	Min	Typ	Max	Unit
Supply Current (Pin3)	Vs = 5V, Ev = 0	ISD	0.7	1.1	1.4	mA
Supply Voltage (Pin3)		Vs	4.5	5	5.5	V
Transmission Distance	IR diode AT205, IF = 400 mA	d	20			m
Output Voltage Low (Pin1)	IosL = 2 mA, f = fo, tp/T = 0.4	VosL			250	mV
Carrier frequency		fo		37.9		kHz
Peak Wavelength		λ		940		nm
Directivity	Angle of half transmission distance	φ1/2		±45		deg

## Application Circuit

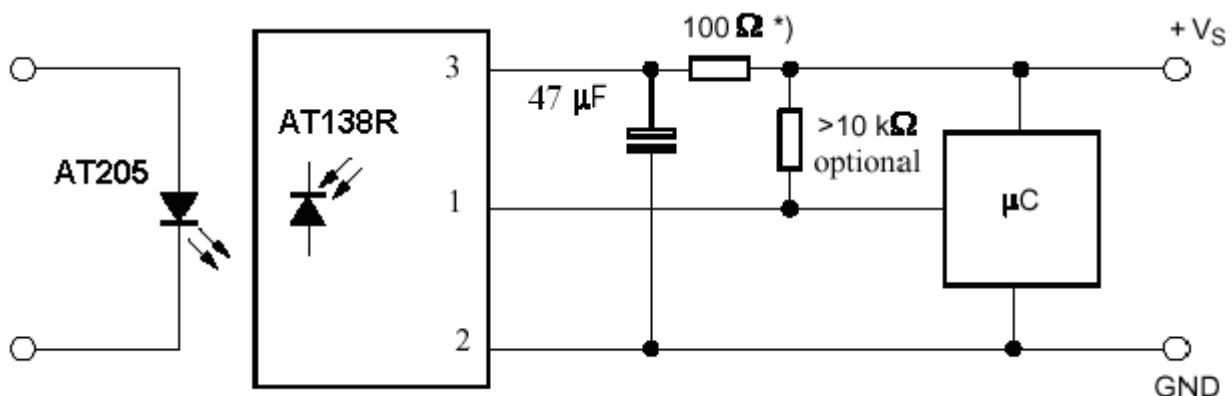

\*) recommended to suppress power supply disturbance

## Package Outline

Dimensions in mm:

